

Wood Stone

OPTIONAL ACCESSORIES

Adjustable Basket Spits: Wood Stone offers several variations of basket spits capable of holding just about anything that you might want to spin on a Rotisserie. Our adjustable clamshell basket is capable of holding a very large rib roast, or can be adjusted to hold several sides of salmon. Our 3 and 4 arm rib baskets are easy to load and unload, and allow the roasting of up to 8 full racks of ribs per spit.

Fish/Vegetable Screens: These heavy-gauge stainless steel screens increase the utility of the basket spits by stabilizing small or delicate items within the basket.

10 Spit Locations: The Mt. Olympus can be ordered with 10 spit locations, as opposed to the standard 6 spit model. The 10 spit model is suitable for chicken only.

Extended, Thermal Flywheel Firebox/Charbroiler: The Mt. Olympus is most commonly ordered with an extended firebox equipped with a 7-square foot Charbroiler constructed of heavy-duty cast iron grates. This option more than doubles the utility of the rotisserie. Furthermore, the firebox can be of a deep or shallow configuration; this should be specified at time of order.

Ash Dolly: Wood Stone's double compartment locking ash dolly is constructed of durable stainless steel and provides a means for safe, clean ash storage and disposal.

Wood Storage Cart: Extra stainless steel wood storage carts can be shipped with the rotisserie. Two carts will fit under the unit.

Moisture Meter: Wood Stone's Mini Ligno E instantly measures the moisture content of any wood.

Exhaust Hood: See exhaust hood section for specification details.

MT. OLYMPUS

Solid Fuel Rotisserie



Job Name	
Model	WS-SFR-6
Item#	
Fuel Type	Solid Fuel



Right-hand drive configuration shown with optional Charbroiler front.

The body of the Mt. Olympus Rotisserie is constructed of polished stainless steel. The Mt. Olympus WS-SFR-(6 or 10) comes with an extremely durable, high temperature ceramic, 7 square foot Charbroiler which includes seven 5 5/8 x 24 inch cast iron grates. The Rotisserie is powered by 1/4HP, variable speed, DC motor with soft start and stop, matched with a robust two-stage gearbox. The 6 spit unit is standard and the spits are 44 inches long, giving the Rotisserie a 36-42 chicken capacity. The optional 10 spit model is suitable only for chicken and has a capacity of 60-70 birds. The controller and motor can be located on either side of the unit; *this must be specified at the time of order*. The Mt. Olympus is easily serviced via an access panel located on the controller side of the unit. A 6.5 cubic foot stainless steel wood cart is provided with each Rotisserie. The cart is designed to allow for easy storage beneath the Rotisserie. An ash shovel and grill tool are also included with the Rotisserie.



An ongoing program of product improvement may require us to change specifications without notice.
Revised August 2009

WOOD STONE CORPORATION
1801 W. Bakerview Rd.
Bellingham, WA 98226 USA

Toll Free (800) 988-8103
Tel (360) 650-1111
Fax (360) 650-1166

info@woodstone-corp.com or visit www.woodstone-corp.com



MT. OLYMPUS

Solid Fuel Rotisserie

Model
WS-SFR-6

Top View

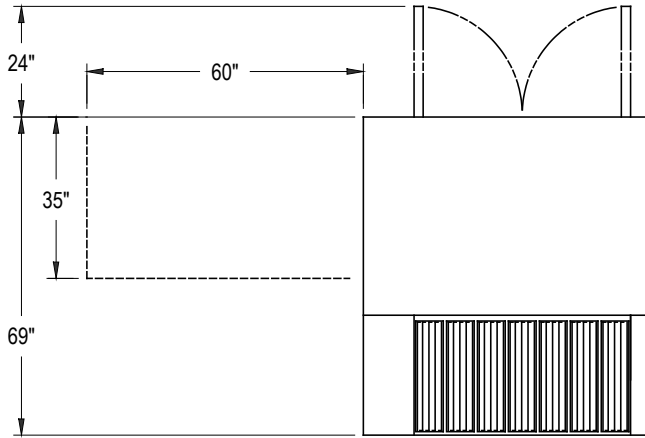

Shown with Optional Charbroiler Front
(Unit Depth without Charbroiler Front is 57")

Rear View

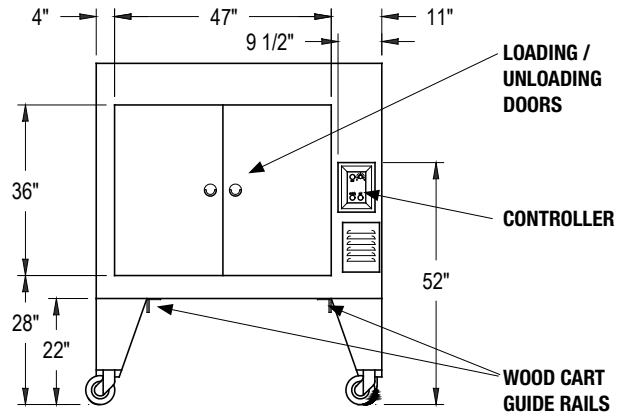

Front View

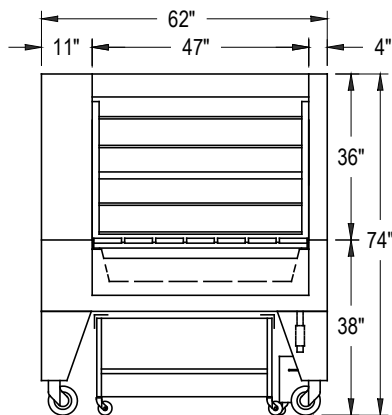

Side View

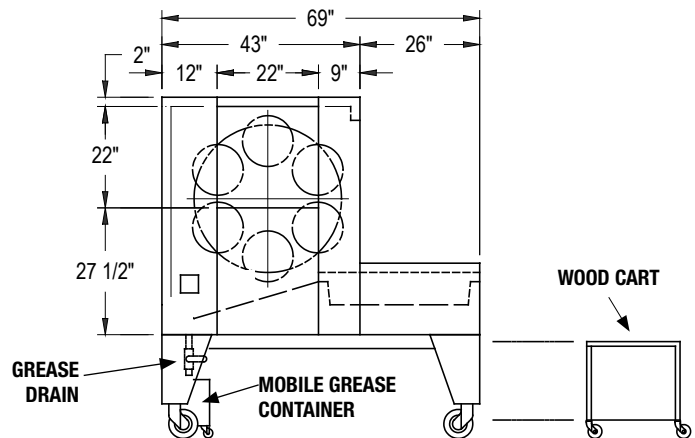

UTILITY REQUIREMENTS

Unit ships with a detachable power cord which plugs into a standard 120VAC 15 Amp outlet. Rotisserie requires 2.5 Amps.

VENTING

A Type 1 hood is required. Hood and ventilation system must be installed and maintained in accordance with NFPA 96, and all relevant national and local codes. Solid fuel cooking equipment must be vented separately from equipment that is not fired by solid fuel.

Unit Shipping Weight

2,900 lbs. (with optional Charbroiler)

2,000 lbs. (without optional Charbroiler)



Wood Stone

An ongoing program of product improvement may require us to change specifications without notice.
Revised August 2009

WOOD STONE CORPORATION
1801 W. Bakerview Rd.
Bellingham, WA 98226 USA

Toll Free (800) 988-8103
Tel (360) 650-1111
Fax (360) 650-1166

info@woodstone-corp.com or visit www.woodstone-corp.com