

Hearth Capacity	
4.5" Bagels	200
16" pizzas	15-20

Optional Accessories

- **Stainless Steel Oven Tool Set**
- **Moisture Meter for Testing Firewood Quality**
- **Stainless Steel Wood Handling Cart**
- **Stainless Steel Ash Dolly**
- **Custom Finishes (stucco-ready, stainless steel, copper)**
- **Stack-Mounted Exhaust Fan**
- **Oven-mounted Exhaust Hood**

The Sumas Mountain Wood-Fired, Stone Hearth Oven

The power of the Sumas Mountain wood-fired oven (weighing 10,000 Lbs) lies in the "thermal flywheel" effect of 7000 pounds of high temperature ceramic. The sole source of heat for this oven is a fire of seasoned hardwood burning within the cooking chamber. The design of this oven and its principle of operation were inspired by the brick ovens of yesteryear. Stored heat is consistently and evenly radiated from the massive hearth. Wood Stone has taken this simple concept and applied progressive engineering to develop the most technically advanced, highest thermal mass oven commercially available.

Once charged with heat, the oven is perfect for restaurant use as well as *commercial production of the highest quality bagels and flatbreads*. The oven features a 43-square foot, 6-inch thick cooking surface, composed of 4,000 pounds of specially formulated high temperature ceramic. The dome of the oven is 2,600 pounds. The thermal mass of this unit is unparalleled by any other commercially available oven. The Sumas Mountain wood-fired oven is a veritable playground for the creative chef. Use the heat stored during the restaurant day to bake pastries and breads all night. The extra-wide (58") doorway provides unobstructed access to the entire interior of the oven for easy loading and unloading.

The Sumas Mountain ships fully assembled (complete with shipping casters) and ready to roll into place. The package includes a stainless steel mantle, an "in floor" thermocouple with digital readout, and stainless steel oven doors for nighttime heat retention.

All Wood Stone, wood-fired ovens (-W) are designed to be easily and fully convertible to radiant-flame gas-fired ovens (-RFG).



Wood Stone

1801 W. Bakerview Rd. Corporation
 Bellingham, WA 98226

Toll Free (800) 988-8103

Tel (360) 650-1111

Fax (360) 650-1166

Sumas Mountain

Wood-Fired
Stone Hearth
Bagel Oven

Model:

WS-MS-8-W

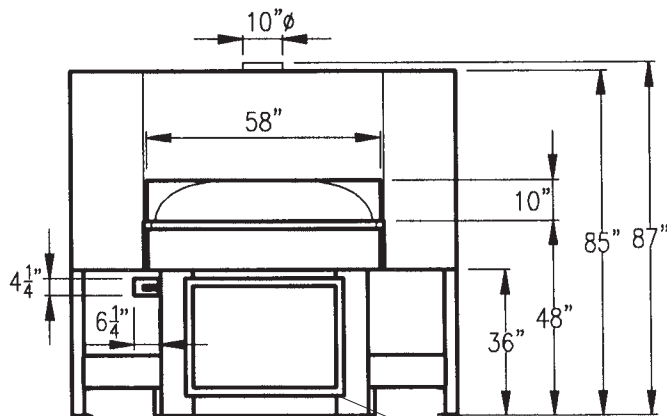

Front Elevation

Oven Mounted
Woodbox

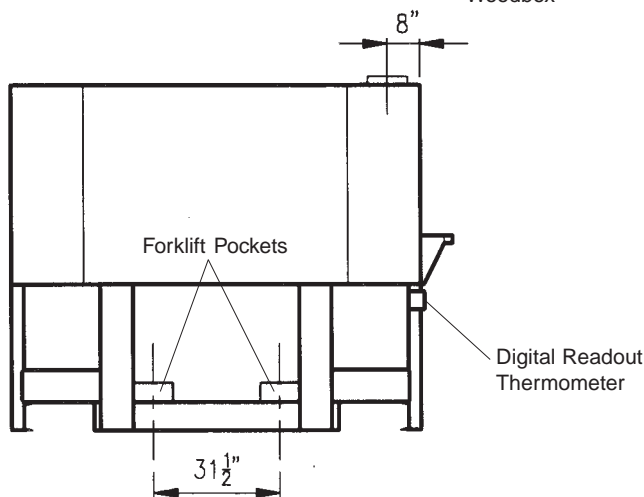

Side Elevation

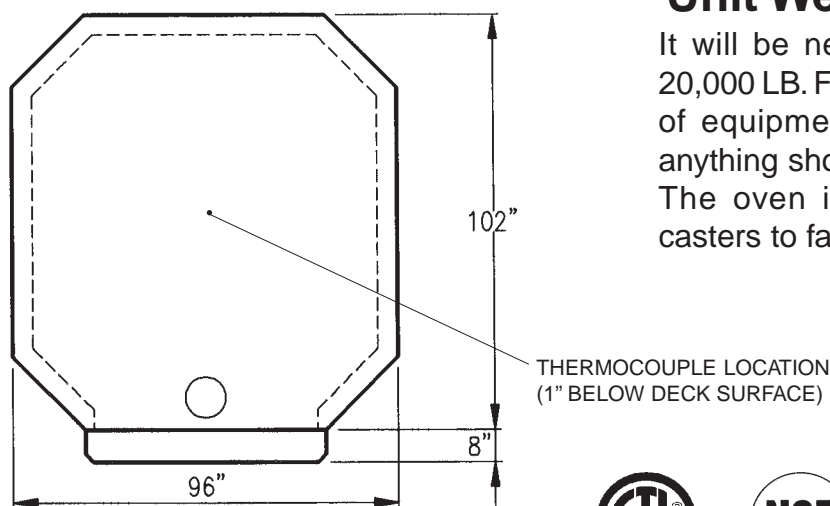

Plan Section at Hearth Level

Required Utilities

120 VAC, 3 Amp electrical service.

Power-ventilated grease duct rated
building heating appliance chimney
or

A Wood Stone exhaust hood or one
constructed and installed in
accordance with NFPA 96.

Unit Weight: 10,000 LBS.

It will be necessary to arrange for an
20,000 LB. Forklift for unloading this piece
of equipment from the delivery truck;
anything short of this will be inadequate.
The oven is equipped with shipping
casters to facilitate ease of placement.



Wood Stone Corporation

1801 W. Bakerview Rd.
Bellingham, WA 98226

Toll Free (800) 988-8103

Tel (360) 650-1111

Fax (360) 650-1166