



### The Sumas Mountain Stone Hearth, Bread Oven

The Sumas Mountain (weighing 10,500 Lbs.) features a 43-square foot, 6-inch thick cooking surface, composed of 4000 pounds of specially formulated high temperature ceramic. The dome of the oven is 2600 pounds. The design of this oven and its principle of operation are inspired by the brick ovens of yesteryear; stored heat is consistently and evenly radiated from the oven's massive hearth and dome. Wood Stone has taken this simple concept and applied progressive engineering to develop the most technically advanced, highest thermal mass, pre-assembled bread oven commercially available. The entire oven (floor and dome) is heated externally by one 100,000 Btu, infrared, gas burner. A separate steam generator is included with the Sumas Mountain bread oven. Various cycles of steam injection and venting can easily be programmed at the discretion of the baker, depending on the desired effect.

The chamber is configured to minimize air movement during the baking process so that the bread within is allowed to develop and bake evenly. The oven is so evenly heated that there is never a need to rotate the bread during the baking cycle. The unique, "reverse dutch door" insures good steam retention during the loading of the oven so that the first loaves loaded have the same beautiful crust as the last. Due to the "thermal flywheel" effect of the ceramics, consistent baking conditions can be sustained indefinitely, even in the face of consecutive loadings of up to 125 pounds of dough.

#### The Oven That Never Cools Down

The first time you turn the oven on and set the thermostatic controller it will take about 48 hours to heat the 7000 pounds of high temperature ceramic to proper hearth baking temperatures. Due to the enormous mass of the hearth and dome, the best fuel efficiency is realized when the oven is never turned off. It takes surprisingly little gas to keep the massive oven up to temperature (a few dollars per day).

The Sumas Mountain ships fully assembled (complete with shipping casters) and ready to roll into place. The package includes a stainless steel mantle, a stainless steel oven tool set, an "in floor" thermometer with a digital readout temperature controller. The oven can be manufactured to burn either Propane (LP) or Natural Gas, *this should be specified at the time of order.*

**11,000 LB Oven with 7000 LB Thermal Mass**  
**High Volume Steam Generator**  
**Lighted Baking Chamber**  
**Stainless Steel Tool Set**



Revised October 2003

An ongoing program of product improvement may require us to change specifications without notice.

### Wood Stone

1801 W. Bakerview Rd. Corporation  
Bellingham, WA 98226

Toll Free (800) 988-8103

Tel (360) 650-1111

Fax (360) 650-1166

# Sumas Mountain

Gas-Fired  
Bread Baking Oven

Model

WS-MS-8-IR-G

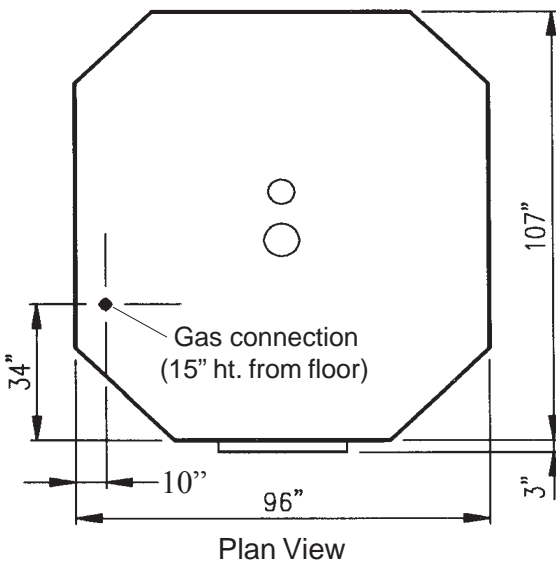
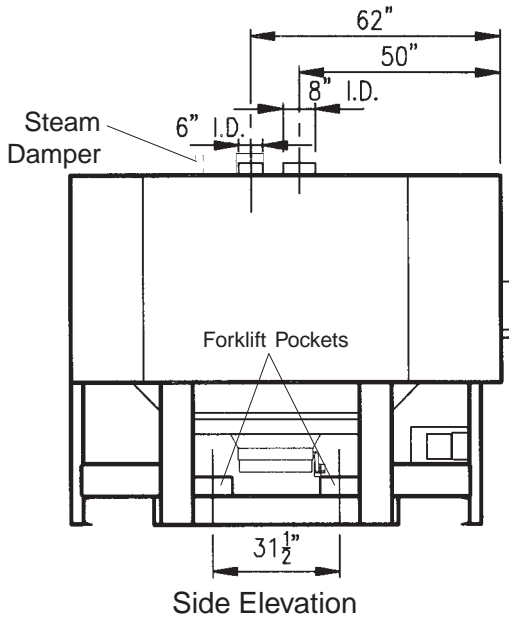
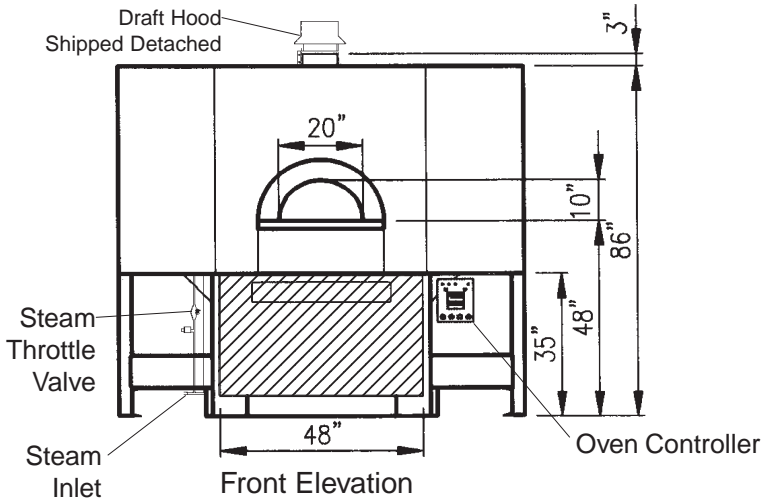

## Model# WS-MS-8-IR-G External Gas Required Utilities

### Power Supply:

For oven

120 VAC, 15 Amp.

For Steam Generator

208 V, 3ph., 50 Amp. Use wire rated for at least 90 degrees C.

and

120 VAC, 15 Amp.

### Plumbing:

3/8" N.P.T. hot water line  
(25 PSI min., 50 PSI max.)

3/8" N.P.T. cold water line  
(25 PSI min., 50 PSI max.)

Drain-pipe, full 2" I.P.S. to flush floor drain capable of receiving 19 L/min. *The drain should be located to receive water from the steam generator as well as the oven.*

100,000 Btu Natural Gas supply, 3/4 inch N.P.T. connector (line must be equipped with an individual appliance shutoff valve; supplied by others).

### Exhaust Ducting:

6" I.D. building heating appliance chimney also listed as a grease duct.

8" I.D. building heating appliance chimney

 Access panel denoted by the shaded area must accessible after installation of the oven.

## Unit Weight: 11,000 LBS.

It will be necessary to arrange for an 20,000 LB. Forklift for unloading this piece of equipment from the delivery truck; anything short of this will be inadequate. The oven is equipped with shipping casters to facilitate ease of placement.



Revised October 2003

**WoodStone** Corporation

1801 W. Bakerview Rd.  
Bellingham, WA 98226

Toll Free (800) 988-8103

Tel (360) 650-1111

Fax (360) 650-1166

An ongoing program of product improvement may require us to change specifications without notice.