

# WoodStone



Oven shown with optional stainless steel mantle.

## MT. BAKER 6'

Stone Hearth Oven



<b>Job Name</b>	
<b>Model</b>	WS-MS-6-RFG-IR
<b>Item#</b>	
<b>Fuel Type</b>	<b>Dual Burner</b>

The Mt. Baker Dual Burner, Gas-Fired oven features a standard door opening 36-inches wide x-10 inches high. The inside diameter of the oven floor is 62-inches, resulting in a 22-square-foot cooking surface. The oven is approved for installation with a 1-inch side clearance to combustible building materials.

The dense, high-temperature ceramic formulation of which the hearth and dome are cast creates a “deep heat sink” within the chamber of the oven. The oven is primarily heated by an easily adjustable (105,000-BTU max.) wall of radiant flame located at the rear of the cooking chamber. An 83,000-BTU thermostatically controlled infrared burner mounted under the floor ensures constant deck temperatures. The combined effect of these heat sources makes the Mt. Baker a very powerful and responsive stone hearth oven.

The 1,600-pound, monolithic, 4-inch thick, cast-ceramic floor sits on 4-inches of rigid insulation. The 1,300-pound, monolithic dome is cast to a thickness of at least 4-inches. The hearth and dome are connected and supported by a carefully tensioned steel exoskeleton, which ensures structural integrity and long life. The body of the oven rests on a 10-gauge steel pan bolted to a heavy-duty 3-inch angle iron stand. The oven is wrapped with at least 2-inches of spun ceramic fiber insulation and enclosed (top and sides) with 16-gauge galvanized steel. The oven arrives completely assembled and ready to set in place.

The oven vents through a flue collar located above the doorway. The Mt. Baker can be direct connected to a power-ventilated, grease-rated chimney or can be vented with a Listed Type 1 exhaust hood, or one constructed in accordance with NFPA 96 and all relevant local and national codes. The oven must be vented in accordance with all relevant local and national codes and in a manner acceptable to the authority having jurisdiction. Ovens ordered without a hood will have a round flue adapter installed to facilitate direct connection to a round duct. A flue adapter is necessary only when the oven will be direct connected.

### Hearth Capacity

8" pizzas	18-22
10" pizzas	14-16
12" pizzas	10-12
16" pizzas	6-8

Assuming 5-minute cook times, the approximate maximum hourly production capacity can be calculated by multiplying the above numbers by 12.

### OPTIONAL ACCESSORIES

- Doorway and Service Panel Extensions
- Stainless Steel or Black Granite Mantles
- Stainless Steel Oven Tools
- Custom Finishes
- Exhaust Fan
- Exhaust Hood
- Wood Burning Option
- Custom Wood Burning Accessories
- Multiple Opening Options



An ongoing program of product improvement may require us to change specifications without notice.  
Revised September 2009

**WOOD STONE CORPORATION**  
1801 W. Bakerview Rd.  
Bellingham, WA 98226 USA

Toll Free (800) 988-8103  
Tel (360) 650-1111  
Fax (360) 650-1166

[info@woodstone-corp.com](mailto:info@woodstone-corp.com) or visit [www.woodstone-corp.com](http://www.woodstone-corp.com)



# MT. BAKER 6'

Dual Burner, Gas-Fired Oven

Model  
**WS-MS-6-RFG-IR**

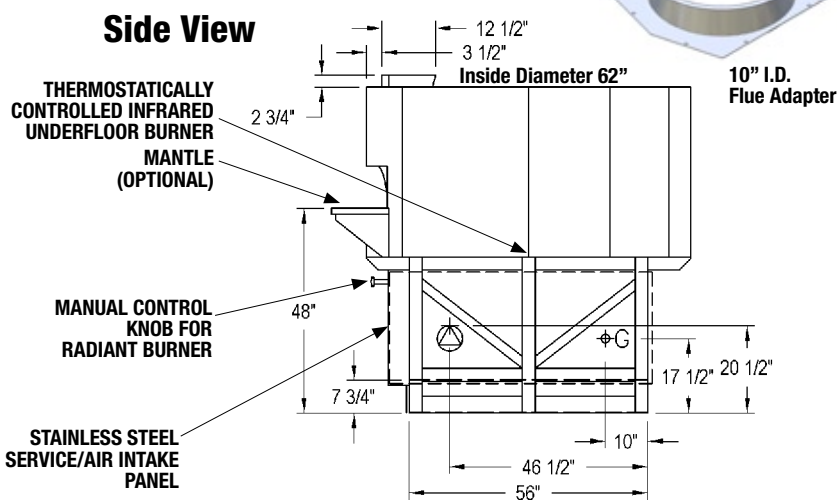
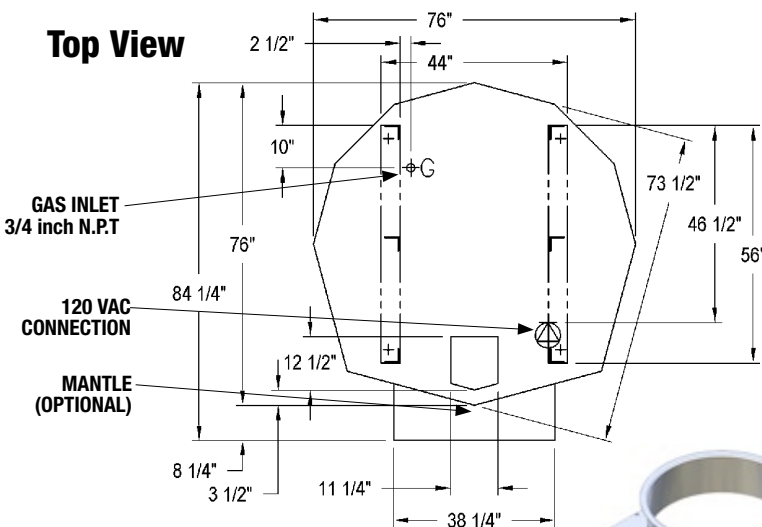
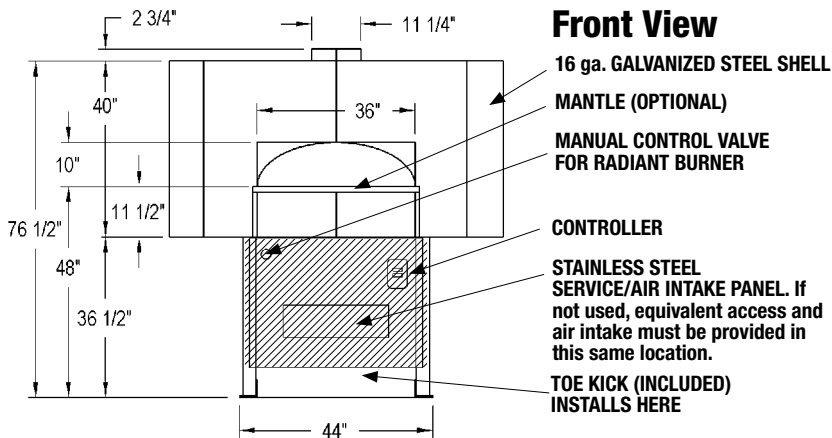

### UTILITIES REQUIRED

1. 120-VAC/ 1.1-AMP Electrical Supply
2. 188,000-BTU Natural Gas Supply  
OR  
159,000-BTU Propane (LP) Supply

### FACADE INFORMATION

1. All facades or enclosures are by others; see installation information for details.
2. Any facade or enclosure below the mantle allow the following:

- a) Unobstructed access 20-inches to each side of centerline for removal of service / intake panel.
- b) Easy access to all controls.
- c) Sufficient combustion air for gas burners; see installation information for details.

### VENTING INFORMATION

The oven vents through a flue collar located above the doorway. The Mt. Baker can be direct connected to a power-ventilated, grease-rated chimney or can be vented with a Listed Type 1 exhaust hood, or one constructed in accordance with NFPA 96 and all relevant local and national codes. The oven must be vented in accordance with all relevant local and national codes and in a manner acceptable to the authority having jurisdiction. Ovens ordered without a hood will have a round flue adapter installed to facilitate direct connection to a round duct. A flue adapter is necessary only when the oven will be direct connected.

**Unit Shipping Weight:  
4,600 lbs.**



**Wood Stone**

An ongoing program of product improvement may require us to change specifications without notice.  
Revised September 2009

### WOOD STONE CORPORATION

1801 W. Bakerview Rd.  
Bellingham, WA 98226 USA

Toll Free (800) 988-8103

Tel (360) 650-1111

Fax (360) 650-1166

info@woodstone-corp.com or visit [www.woodstone-corp.com](http://www.woodstone-corp.com)