

Wood Stone



Oven shown with optional stainless steel mantle.

MT. BAKER 6'

Stone Hearth Oven



Job Name

Model

WS-MS-6-RFG-W

Item#

Fuel Type

Gas-Fired / Wood Optional

Hearth Capacity

8" pizzas	18-22
10" pizzas	14-16
12" pizzas	10-12
16" pizzas	6-8

Assuming 5-minute cook times, the approximate maximum hourly production capacity can be calculated by multiplying the above numbers by 12.

OPTIONAL ACCESSORIES

- Doorway and Service Panel Extensions
- Stainless Steel or Black Granite Mantles
- Stainless Steel Oven Tool Sets
- Custom Finishes
- Exhaust Fan
- Exhaust Hood
- Custom Wood Burning Accessories
- Multiple Opening Option

The Mt. Baker Radiant Flame, Gas-Fired oven features a standard door opening 36-inches wide x 10-inches high. The inside diameter of the oven floor is 62-inches, resulting in a 22-square-foot cooking surface. The oven is ETL Listed for installation with a 1-inch side clearance to combustible building materials.

The dense, high-temperature ceramic formulation of which the hearth and dome are cast creates a "deep heat sink" within the chamber of the oven. The oven is heated by an easily adjustable (105,000-BTU max.) wall of radiant flame located at the rear of the cooking chamber. The user also has the option of building a small wood fire on either side of the cooking chamber for additional ambience and flavor.

The 1,600-pound, monolithic, 4-inch thick, cast-ceramic floor sits on 4-inches of rigid insulation. The 1,300-pound, monolithic dome is also cast to a thickness of at least 4-inches. The hearth and dome are connected and supported by a carefully tensioned steel exoskeleton, which ensures structural integrity and long life. The body of the oven rests on a 10-gauge steel pan bolted to a heavy-duty, 3-inch angle iron stand. The oven is wrapped with at least 2-inches of spun ceramic fiber insulation and enclosed (top and sides) with 16-gauge galvanized steel. The oven arrives completely assembled and ready to set in place.

The oven can be manufactured to burn either propane or natural gas; this must be specified at the time of order.

The oven vents through a flue collar located above the doorway. The Mt. Baker is listed for direct connection to a power-ventilated, grease-rated chimney or through a Listed Type 1 exhaust hood or one constructed in accordance with NFPA 96 and all relevant local and national codes. The oven must be vented as a solid fuel appliance, in accordance with all relevant local and national codes and in a manner acceptable to the authority having jurisdiction. Ovens ordered without a hood will have a round flue adapter installed to facilitate direct connection to a round duct. A flue adapter is necessary only when the oven will be direct connected. Models that utilize wood as a fuel source must be vented as a solid fuel appliance.

The Mt. Baker Radiant Flame gas oven can be manufactured to be fully and easily convertible to a Dual Temperature gas oven (this must be specified at time of order).



Wood Stone

An ongoing program of product improvement may require us to change specifications without notice.
Revised September 2009

WOOD STONE CORPORATION

1801 W. Bakerview Rd.
Bellingham, WA 98226 USA

Toll Free (800) 988-8103

Tel (360) 650-1111

Fax (360) 650-1166

info@woodstone-corp.com or visit www.woodstone-corp.com



MT. BAKER 6'

Radiant Flame, Gas-Fired / Wood Optional Oven

Model
WS-MS-6-RFG-W

Front View

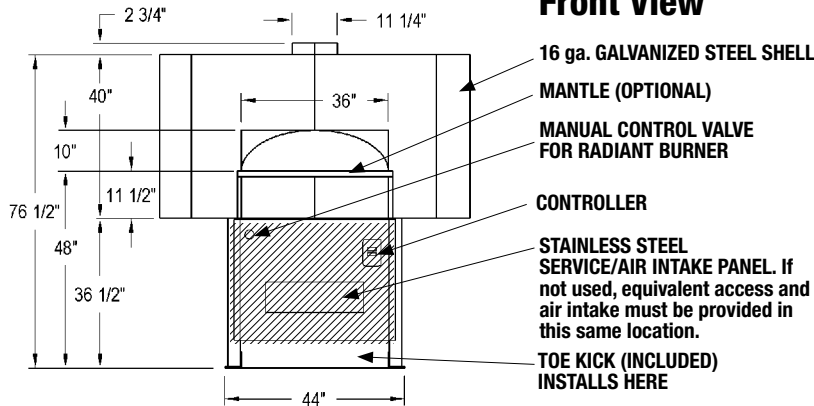

Top View

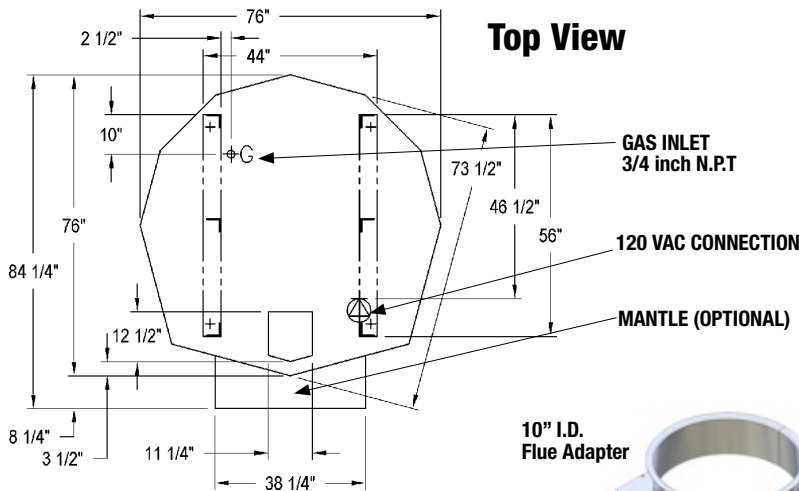

Side View

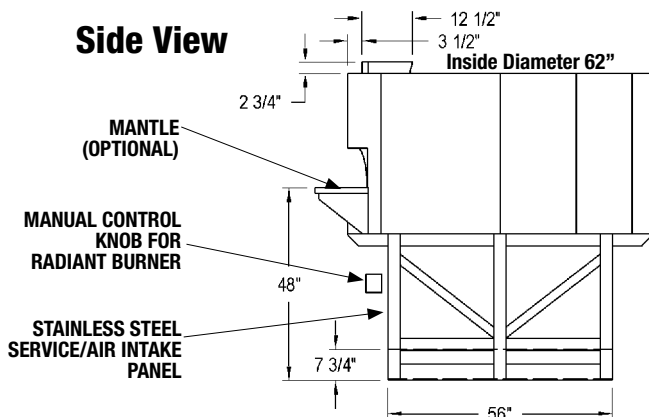

UTILITIES REQUIRED

1. 120-VAC/ 1.1-AMP Electrical Supply
2. 105,000-BTU Natural Gas Supply
OR
94,000-BTU Propane (LP) Supply

FACADE INFORMATION

1. All facades or enclosures are by others; see installation information for details.
2. Any facade or enclosure below the mantle allow the following:

- a) Unobstructed access 20-inches to each side of centerline for removal of service / intake panel.
- b) Easy access to all controls.
- c) Sufficient combustion air for gas burners; see installation information for details.

VENTING INFORMATION

The oven vents through a flue collar located above the doorway. The Mt. Baker is listed for direct connection to a power-ventilated, grease-rated chimney or through a Listed Type 1 exhaust hood or one constructed in accordance with NFPA 96 and all relevant local and national codes. The oven must be vented as a solid fuel appliance, in accordance with all relevant local and national codes and in a manner acceptable to the authority having jurisdiction. Ovens ordered without a hood will have a round flue adapter installed to facilitate direct connection to a round duct. A flue adapter is necessary only when the oven will be direct connected. Models that utilize wood as a fuel source must be vented as a solid fuel appliance.

**Unit Shipping Weight:
4,600 lbs.**



Wood Stone

An ongoing program of product improvement may require us to change specifications without notice.
Revised September 2009

WOOD STONE CORPORATION

1801 W. Bakerview Rd.
Bellingham, WA 98226 USA

Toll Free (800) 988-8103

Tel (360) 650-1111

Fax (360) 650-1166

info@woodstone-corp.com or visit www.woodstone-corp.com