

# Wood Stone



Oven shown with optional stainless steel mantle.

## MT. CHUCKANUT 4'

Stone Hearth Oven



<b>Job Name</b>	
<b>Model</b>	WS-MS-4-RFG-IR-W
<b>Item#</b>	
<b>Fuel Type</b>	<b>Dual Burner, Gas-Fired / Wood Optional</b>

The Mt. Chuckanut Dual Burner, Gas-Fired / Wood Optional oven features a standard door opening 20-inches wide x 10-inches high. The inside diameter of the oven floor is 37-inches, resulting in a 9-square-foot cooking surface. The oven is approved for installation with a 1-inch side clearance to combustible building materials.

The dense, high-temperature ceramic formulation of which the hearth and dome are cast creates a "deep heat sink" within the chamber of the oven. The oven is primarily heated by an easily adjustable (68,000-BTU max.) wall of radiant flame located at the rear of the cooking chamber. A 47,000-BTU, thermostatically controlled infrared burner mounted under the floor ensures constant deck temperatures. The user also has the option of building a small wood fire on either side of the cooking chamber for additional ambiance and flavor. The combined effect of these heat sources makes the Mt. Chuckanut a very powerful and responsive stone hearth oven.

The 650-pound, monolithic, 4-inch thick cast-ceramic floor sits on 4-inches of rigid insulation. The 700-pound, monolithic dome is cast to a thickness of at least 4-inches. The hearth and dome are connected and supported by a carefully tensioned steel exoskeleton, which ensures structural integrity and long life. The body of the oven rests on a 10-gauge steel pan bolted to a heavy-duty, 3-inch angle iron stand. The oven is wrapped with at least 2-inches of spun ceramic fiber insulation and enclosed (top and sides) with 16-gauge galvanized steel. The oven arrives completely assembled and ready to set in place.

The oven can be manufactured to burn either propane or natural gas; this must be specified at the time of order.

The Mt. Chuckanut can be direct connected to a power-ventilated, grease-rated chimney or can be vented using a Listed Type 1 exhaust hood or one constructed in accordance with all relevant local and national codes. The oven must be vented as a solid fuel appliance, in accordance with all relevant local and national codes, and in a manner acceptable to the authority having jurisdiction.

### Hearth Capacity

8" pizzas	8-10
10" pizzas	5-6
12" pizzas	4
16" pizzas	1-2

Assuming 5-minute cook times, the approximate maximum hourly production capacity can be calculated by multiplying the above numbers by 12.

**Note:** Highlighted capacities are considered an operational challenge.

### OPTIONAL ACCESSORIES

- Doorway and Service Panel Extensions
- Stainless Steel or Black Granite Mantle
- Stainless Steel Oven Tools
- Custom Finishes
- Exhaust Fan
- Exhaust Hood
- Custom Wood Burning Accessories



An ongoing program of product improvement may require us to change specifications without notice.  
Revised August 2009

**WOOD STONE CORPORATION**  
1801 W. Bakerview Rd.  
Bellingham, WA 98226 USA

Toll Free (800) 988-8103  
Tel (360) 650-1111  
Fax (360) 650-1166

[info@woodstone-corp.com](mailto:info@woodstone-corp.com) or visit [www.woodstone-corp.com](http://www.woodstone-corp.com)



# MT. CHUCKANUT 4'

Dual Burner, Gas-Fired / Wood Optional Oven

Model

WS-MS-4-RFG-IR-W

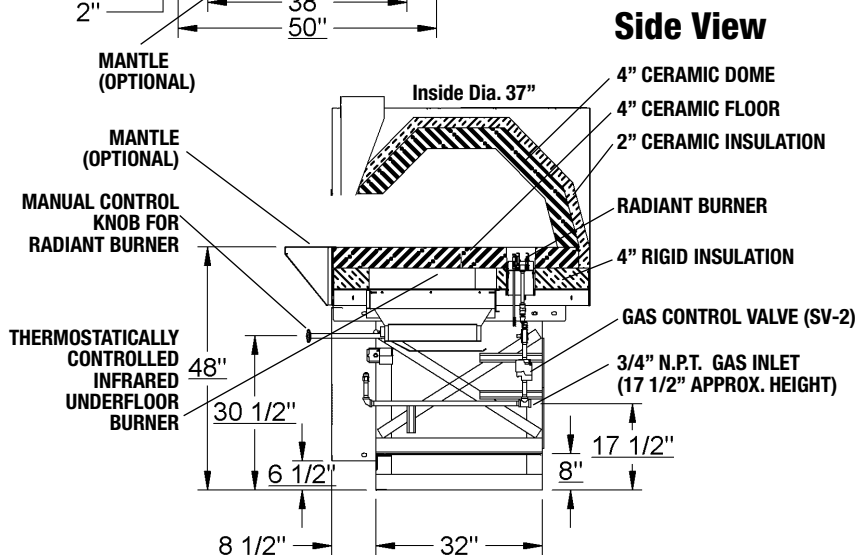
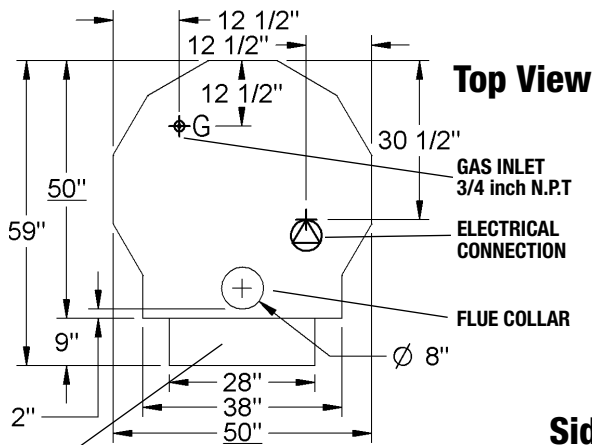
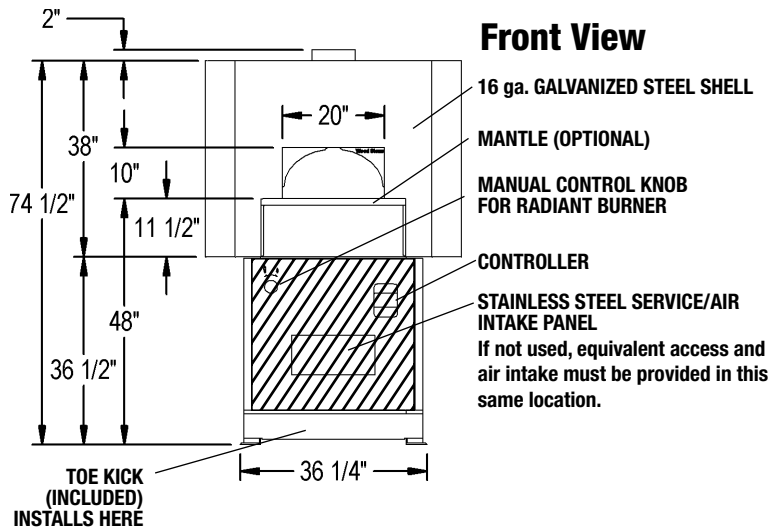

### UTILITIES REQUIRED

1. 120-VAC/ 1.1 AMP Electrical Supply- Connection made beneath oven as shown.
2. 115,000-BTU Natural Gas Supply OR 102,000-BTU Propane (LP) Supply

### FACADE INFORMATION

1. All facades or enclosures are by others; see installation information for details.
2. Any facade or enclosure below the mantle must allow the following:

- a) Unobstructed access 16-inches to each side of centerline for removal of service / intake panel.
- b) Easy access to all controls.
- c) Sufficient combustion air for gas burner; see installation information for details.

### VENTING INFORMATION

The Mt. Chuckanut can be direct connected to a power-ventilated, grease-rated chimney or can be vented using a Listed Type 1 exhaust hood or one constructed in accordance with all relevant local and national codes. The oven must be vented as a solid fuel appliance, in accordance with all relevant local and national codes, and in a manner acceptable to the authority having jurisdiction.

**Unit Shipping Weight:  
2,400 Lbs.**



**Wood Stone**

An ongoing program of product improvement may require us to change specifications without notice.  
Revised August 2009

**WOOD STONE CORPORATION**  
1801 W. Bakerview Rd.  
Bellingham, WA 98226 USA

Toll Free (800) 988-8103  
Tel (360) 650-1111  
Fax (360) 650-1166

info@woodstone-corp.com or visit [www.woodstone-corp.com](http://www.woodstone-corp.com)