

# Wood Stone



## OPTIONAL ACCESSORIES

- Available in Round, Square and Octagonal models
- Stainless Steel Tools
- Caster Riser Assembly to enable installation into a 910 mm tall cooking suite

## TANDOOR 31"

Gas-Fired Tandoor



<b>Job Name</b>	
<b>Model</b>	WS-GFT-31
<b>Item#</b>	
<b>Fuel Type</b>	<b>Gas-Fired</b>

The Wood Stone gas-fired Tandoor utilizes an interior cooking vessel which is cast from the same ultra-strong, high temperature ceramic technology that we use for our stone hearth ovens.

This interior cooking unit has a 305-mm opening and is encased in an insulated, stainless steel cabinet. The Tandoor is topped with an attractive and durable quartz composite that simulates the look of granite. The entire unit sits on heavy-duty casters.

The gas burner uses a pilot safety valve, equipped with a Piezo-Electric ignition system. The heat output of the burner can be adjusted from its highest setting to completely turned off (or any setting in between), by turning the throttle control knob which is conveniently located on the top of the unit.

The Tandoor comes with a lightweight, ventilated lid for faster heat-up. A removable drip/debris pan is located beneath the unit.

The Wood Stone Tandoor can be configured to burn Natural gas or Propane; *this must be specified at the time of order*. Restraint anchors for a flexible gas supply line restraining cable are located beneath the unit. The 780-mm round footprint of this unit makes it easy to fit through standard doors and into an existing cook line.

The unit may be ordered with a caster riser assembly to increase the height of the Tandoor to 910 mm, to enable easy installation into a cooking suite.

This appliance must be installed under an exhaust hood, in accordance with all relevant local and national codes, and in a manner acceptable to the authority having jurisdiction. Please contact Wood Stone for more detailed information.



An ongoing program of product improvement may require us to change specifications without notice.  
Revised July 2010

## WOOD STONE CORPORATION

1801 W. Bakerview Rd.  
Bellingham, WA 98226 USA

Tel +1(360) 650-1111  
Fax +1(360) 650-1166

[info@woodstone-corp.com](mailto:info@woodstone-corp.com) or visit [www.woodstone-corp.com](http://www.woodstone-corp.com)



# TANDOOR 31"

Gas-Fired Tandoor

Model

# WS-GFT-31

### Top View (Round Model)

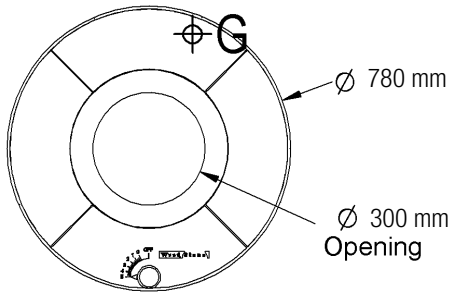

### Top View (Square Model)

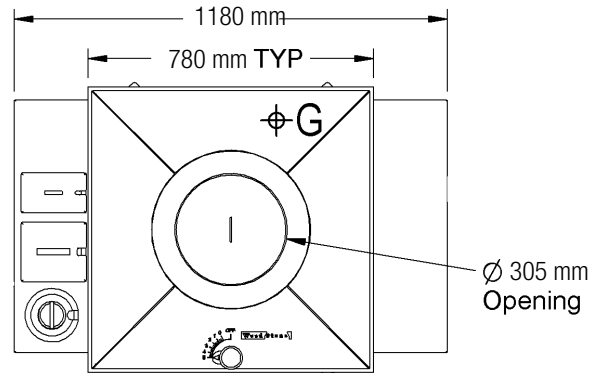

### Top View (Octagonal Model)

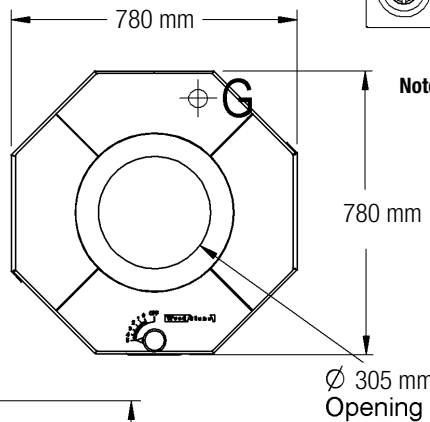

Note: Square model shown with optional shelves and pan rails

### Front View

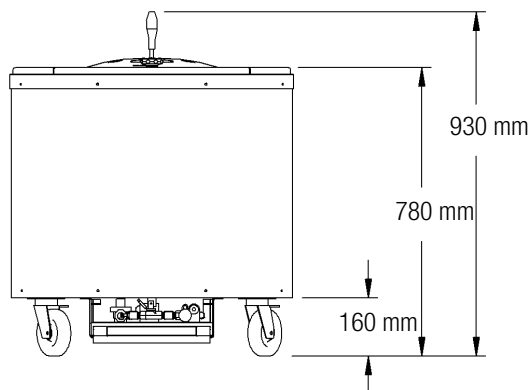

### Side View

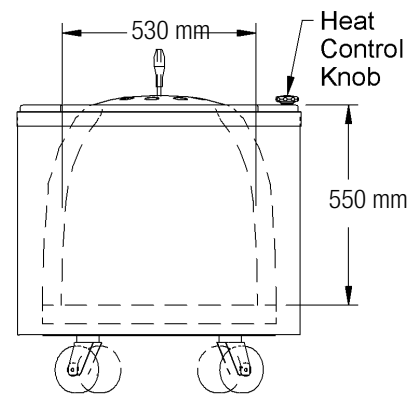

#### UTILITY SPECIFICATIONS

Gas-1/2-inch (13 mm) NPT gas inlet (female threaded)   
 40,000 Btu (11.7 kW) Natural Gas or  
 40,000 Btu (11.7 kW) Propane.  
 Gas type must be specified when ordering.

Gas connection should be made using an approved flexible connector and the unit must be restrained in accordance with all relevant local and/or national codes. Gas connection is made beneath the unit at the rear.

#### VENTING

This appliance must be installed under an exhaust hood, in accordance with all relevant local and national codes, and in a manner acceptable to the authority having jurisdiction. Please contact Wood Stone for more detailed information.

## Unit Shipping Weight: 340 Kg



An ongoing program of product improvement may require us to change specifications without notice.  
 Revised July 2010

#### WOOD STONE CORPORATION

1801 W. Bakerview Rd.  
 Bellingham, WA 98226 USA

Tel +1(360) 650-1111  
 Fax +1(360) 650-1166

info@woodstone-corp.com or visit [www.woodstone-corp.com](http://www.woodstone-corp.com)