

Wood Stone

Fire Deck 6045 Gas-fired, or Multi-Fuel Stone Hearth Deck Oven

Job Name: _____

Model: WS-FD-6045

Item #: _____



Right-hand configuration shown with optional stainless steel storage box.

Hearth Capacity	
8" pizzas	16
10" pizzas	10
12" pizzas	6
16" pizzas	4

Optional Accessories

- **Stainless Steel Storage Box**
- **Stainless Steel Oven Tool Set (with stainless steel hangers)**
- **Stack-Mounted Exhaust Fan**
- **Custom Oven-Mounted Exhaust Hood**
- **Prepared for Facade Application**
- **Temporary Rigging Casters**
- **Configured for Wood Burning**
(Wood burning models must be vented for solid-fuel)
- **Wood Stone also carries a full line of accessories for stone-hearth cooking**

The Wood Stone Fire Deck 6045

The Fire Deck 6045 features a standard door opening 34 inches wide x 10 inches high. The cooking surface is 40 inches wide, and 38 inches deep, resulting in 9 square feet of usable deck space. The dense, high temperature ceramic formulation of which the hearth and dome are cast creates a "deep heat sink" within the chamber of the oven. The chef is protected from the heat of the chamber by the ceramic glass door/heat shield. The heat shield glides smoothly and easily using a simple counterweight, and can be safely left in any position. Whether it is open or closed, the operator and the customers can see into the brightly illuminated chamber. The Fire Deck is unique among deck ovens in that the oven operates efficiently with the door open or closed.

The Fire Deck 6045 is available in a variety of burner and fuel configurations. The standard unit has a manually adjustable wall of radiant flame on one side of the oven chamber (*specify right or left at time of order*), as well as a thermostatically controlled gas infrared burner beneath the oven deck. Either or both of these burners can be omitted to accommodate the use of wood as a fuel source.

The 750-pound, monolithic, cast-ceramic floor sits on 4 inches of rigid insulation and is poured to a thickness of 4 inches. The 950-pound, monolithic dome is also cast to a thickness of 4 inches. The hearth and dome are connected by a carefully tensioned stainless steel exoskeleton, which ensures structural integrity and long life. The oven's ceramic dome is wrapped with at least 2 inches of spun ceramic fiber insulation and enclosed (top and sides) with 16-gauge steel. The body of the oven rests on a 10-gauge steel pan welded to a heavy-duty frame. A stainless steel storage compartment is optional and can be provided in the support frame. The oven arrives completely assembled and may be accompanied by a set of temporary rigging casters (optional) to aid in moving the oven into place.

The Fire Deck should be vented using a Type 1 exhaust hood constructed and installed in accordance all relevant local and national codes.



Wood Stone

Corporation
1801 W. Bakerview Rd.

Bellingham, WA 98226 USA

Toll Free (800) 988-8103

Tel (360) 650-1111

Fax (360) 650-1166

Fire Deck

Stone Hearth, Multi-Fuel,
Baking and Roasting Oven

Model

WS-FD-6045

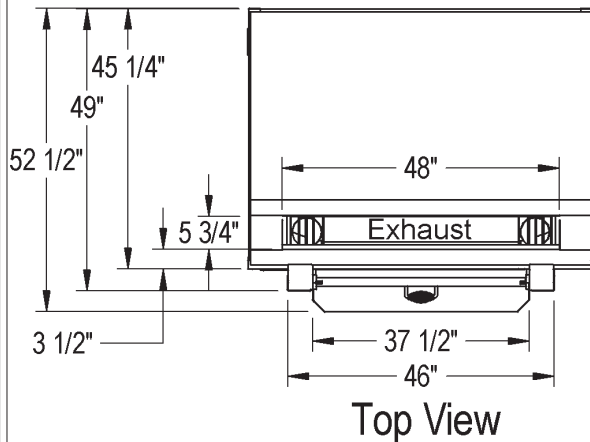

VERY IMPORTANT!! This oven is available in a left or right configuration. The configuration corresponds to the location of the radiant flame. The figures on this page show a LEFT-hand configuration. Everything about a RIGHT-hand configured Fire Deck 6045 will be a mirror image of the LEFT-hand version.

Guide to Fire Deck Model #s

	Underfloor IR Burner	Left-side Flame Burner	Right-side Flame Burner	Wood Fire Optional	Wood Fire Mandatory	Natural Gas	Propane
WS-FD-6045-RFG-L-IR	X	X		-W		NG	LP
WS-FD-6045-RFG-R-IR	X		X	-W		NG	LP
WS-FD-6045-W-IR	X				X	NG	LP
WS-FD-6045-W					X		

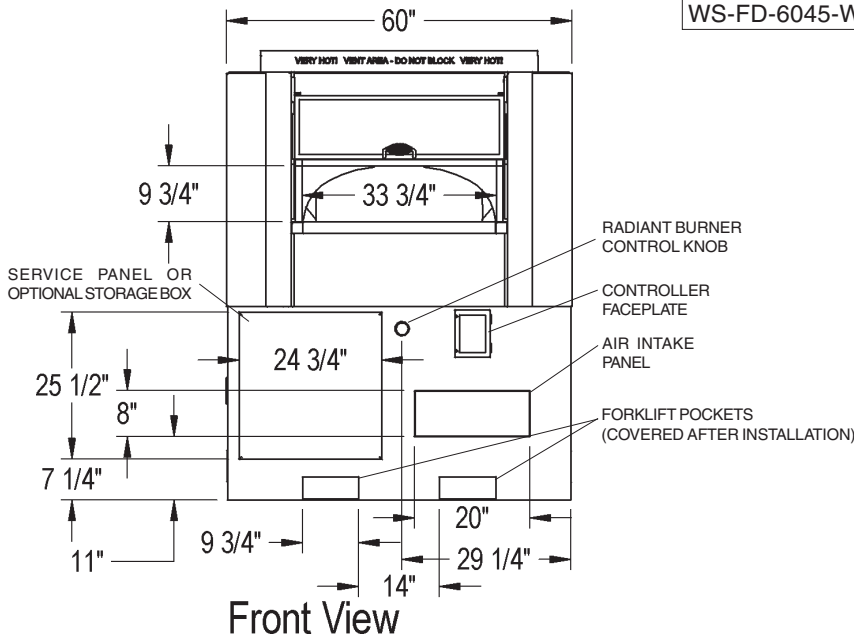

UTILITIES REQUIRED

- 120 VAC/ 4 AMP electrical connection
 - 135,000 BTU Natural Gas supply
OR
120,000 BTU Propane (LP) supply
- The oven's gas inlet is 3/4" N.P.T. Female*

VENTING INFORMATION

Intended for installation with a Type 1 exhaust hood constructed and installed in accordance with all relevant local and national codes.

Heat Shield Swing Detail

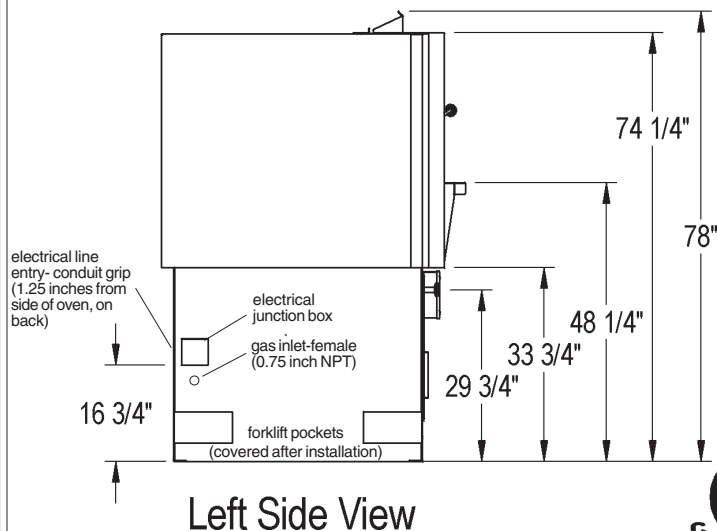
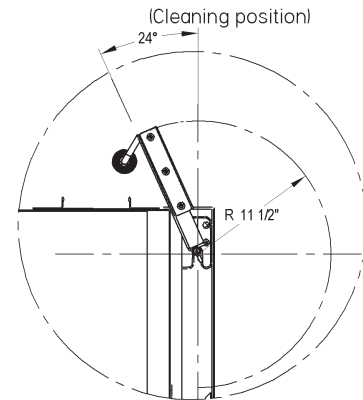

Unit Shipping Weight: 3,200 lbs.

An ongoing program of product improvement may require us to change specifications without notice.



Wood Stone

1801 W. Bakerview Rd. Corporation
Bellingham, WA 98226 USA

Toll Free (800) 988-8103

Tel (360) 650-1111

Fax (360) 650-1166

Revised October 2007

Call Us Toll Free 1-800-988-8103 www.woodstone-corp.com