

# Wood Stone



## PLANCHA

High Temperature Cook Surface



<b>Job Name</b>	
<b>Model</b>	WS-PL-36-37-4-CT
<b>Item#</b>	
<b>Fuel Type</b>	<b>Electric</b>

### OPTIONS

- Counter-Top models
- Cabinet Base models
- Custom Configurations Available

### COOKING

The Wood Stone Plancha is a full range cooking appliance. For example, use the Plancha during the morning for prep work, then clean it off for service for searing or sautéing. After service, or as you are cooking on the other zones, you can use the Plancha for stocks or other long gentle simmers. In a kitchen with fluctuating work loads, if you have a suite of Planchas, it is possible to turn off unused zones during slow times and operate with one cook. During busy times, have a chef at each Plancha preparing different items.

The Wood Stone Plancha is a highly responsive, high temperature, consistent cooking surface, backed by Wood Stone's reputation for quality engineered equipment.

With a small footprint, the unit measures 36 inches x 37 inches. The Plancha is made from polished steel and ships as a stand alone unit with legs to allow for easy installation on a non-combustible counter-top.

The Plancha's polished steel surface can be used as a direct contact cooking surface like a griddle for searing or sautéing, or heated up to 850 degrees F so that it functions more like an open burner or French Top.

With thermostatically controlled electric zones, the Wood Stone Plancha is an efficient piece of equipment that radiates less heat than a gas-fired open burner range resulting in a cooler kitchen.

The Plancha is available in counter-top or cabinet models. The standard configuration is a 4 zone electric unit. Cleaning the Wood Stone Plancha is quick and easy with grease and debris collection areas on all 4 sides.



**Wood Stone**

An ongoing program of product improvement may require us to change specifications without notice.  
Revised October 2009

### WOOD STONE CORPORATION

1801 W. Bakerview Rd.  
Bellingham, WA 98226 USA

Toll Free (800) 988-8103

Tel (360) 650-1111

Fax (360) 650-1166

[info@woodstone-corp.com](mailto:info@woodstone-corp.com) or visit [www.woodstone-corp.com](http://www.woodstone-corp.com)



# PLANCHA GRILL

High Temperature Cook Surface

Model

WS-PL-36-37-4-CT

### Top View

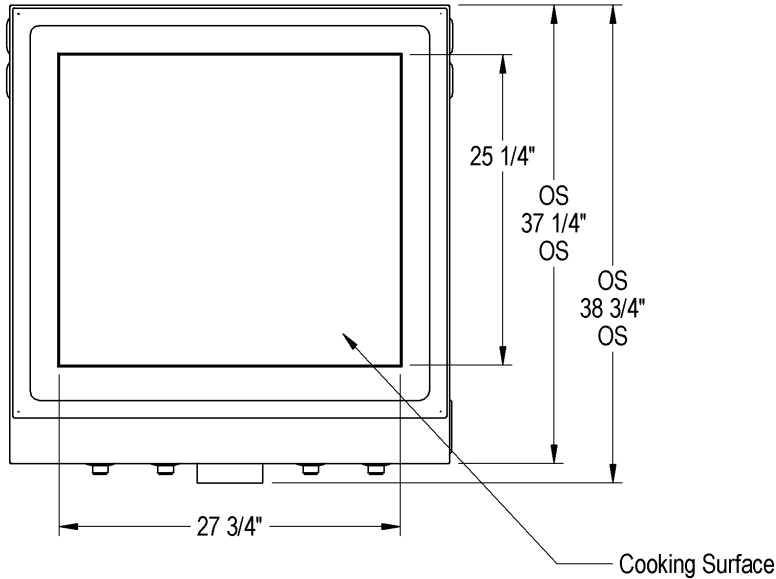

### Isometric View

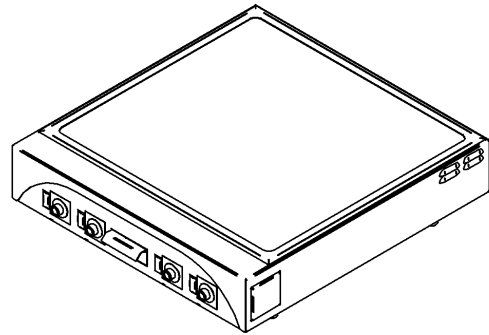

### Front View

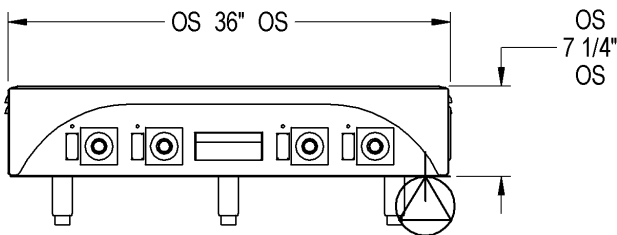

### Side View

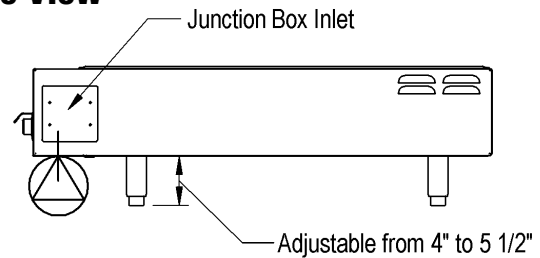

#### UTILITIES SPECIFICATIONS

##### COUNTER-TOP MODELS

##### Electrical

208 VAC, 1 Phase, 11,500 Watts Total, 50/60 Hz

**Note:** This unit comes equipped with 2 power supply cords with NEMA 6-50

plugs that must be connected to 2 individual branch circuits (2 Wire Plus Ground), each rated at 40 Amps each.

##### VENTING INFORMATION

This appliance must be vented in accordance with NFPA 96.

**Unit Shipping Weight: 480 Lbs.**



An ongoing program of product improvement may require us to change specifications without notice. Revised October 2009

#### WOOD STONE CORPORATION

1801 W. Bakerview Rd.  
Bellingham, WA 98226 USA

Toll Free (800) 988-8103

Tel (360) 650-1111

Fax (360) 650-1166

info@woodstone-corp.com or visit [www.woodstone-corp.com](http://www.woodstone-corp.com)