

Wood Stone



Oven shown with optional stainless steel mantle.

NAPLES DUAL-TEMP

Stone Hearth Oven



Job Name

Model

WS-MS-6-RFG-IR-NAP

Item#

Fuel Type

Dual Gas / Dual-Temp

Hearth Capacity

8" pizzas	18-22
10" pizzas	11-13
12" pizzas	8-10
16" pizzas	6-8

OPTIONAL ACCESSORIES

- Stainless Steel or Black Granite Mantle
- Decorative Oven Mounted Wood box
- Stainless Steel Oven Tool Set (with stainless steel hangers)
- Custom Finishes (stucco-ready, stainless steel, copper, and more)
- Stack Mounted Exhaust Fan
- Custom Oven Mounted Exhaust Hood
- Configured for Wood Burning (changes model suffix to RFG-IR-W)

The Naples Style dual-temperature, gas-fired oven design is based upon our highly successful Mount Baker oven. It features an increased BTU radiant flame gas burner for those seeking to produce a 'Naples' style pizza from a gas-fired oven. This burner can optionally be mounted on either the left or right side of the cooking chamber.

The oven door opening is 36 inches wide. Door height is reduced to 7.5 inches to achieve Naples style temperatures more easily. The inside diameter of the oven floor is 62 inches, resulting in a 21-square-foot cooking surface. The oven is approved for installation with a 1 inch side clearance to combustible building materials.

The dense, high-temperature ceramic formulation of which the hearth and dome are cast creates a "deep heat sink" within the chamber of the oven. The oven is primarily heated by an easily adjustable (135,000 BTU max.) wall of radiant flame located at the side of the cooking chamber. An 83,000-BTU thermostatically controlled infrared burner mounted under the floor ensures constant deck temperatures. The combined effect of these heat sources make this a very powerful and responsive stone hearth oven.

The 1,600-pound, monolithic, cast-ceramic floor sits on 4 inches of rigid insulation and is poured to a thickness of 4 inches. The 1,300-pound, monolithic dome is cast to a thickness of 4 inches. The hearth and dome are connected and supported by a carefully tensioned stainless steel exoskeleton, which ensures structural integrity and long life. The body of the oven rests on a 10-gauge steel pan bolted to a heavy-duty 3 inch angle iron stand. The oven is wrapped with at least 2 inches of spun ceramic fiber insulation and enclosed (top and sides) with 16-gauge galvanized steel. The oven arrives completely assembled and ready to set in place.

The oven can be manufactured to burn either propane or natural gas; *this must be specified at the time of order.*

The oven vents through a 10 inch O.D. flue collar located above the doorway. The Naples oven can be direct connected to a power-ventilated, grease-rated chimney or can be vented with a Listed Type 1 exhaust hood, or one constructed in accordance with NFPA 96 and all relevant local and national codes. The oven must be vented in accordance with all relevant local and national codes and in a manner acceptable to the authority having jurisdiction.



Wood Stone

An ongoing program of product improvement may require us to change specifications without notice.
Revised February 2010

WOOD STONE CORPORATION

1801 W. Bakerview Rd.
Bellingham, WA 98226 USA

Toll Free (800) 988-8103

Tel (360) 650-1111

Fax (360) 650-1166

info@woodstone-corp.com or visit www.woodstone-corp.com





NAPLES DUAL-TEMP

Stone Hearth Oven

Model

WS-MS-6-RFG-IR-NAP

UTILITIES REQUIRED

1. 120 VAC/ 1.1 AMP Electrical Supply 
 2. 218,000 BTU Natural Gas Supply 
- OR
available for LP - call factory

FACADE INFORMATION

1. All facades or enclosures are by others; see installation information for details.
2. Any facade or enclosure below the mantle allow the following:
 - a) Unobstructed access 20 inches to each side of centerline for removal of service / intake panel.
 - b) Easy access to all controls.
 - c) Sufficient combustion air for gas burners; see installation information for details.

VENTING INFORMATION

The oven vents through a 10 inch O.D. flue collar located above the doorway. The Naples oven can be direct connected to a power-ventilated, grease-rated chimney or can be vented with a Listed Type 1 exhaust hood, or one constructed in accordance with NFPA 96 and all relevant local and national codes. The oven must be vented in accordance with all relevant local and national codes and in a manner acceptable to the authority having jurisdiction.

**Unit Shipping Weight:
4,600 lbs.**

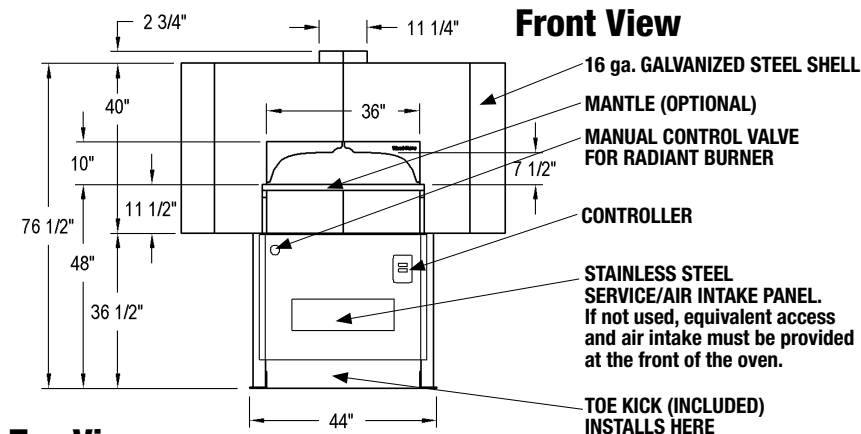

Top View

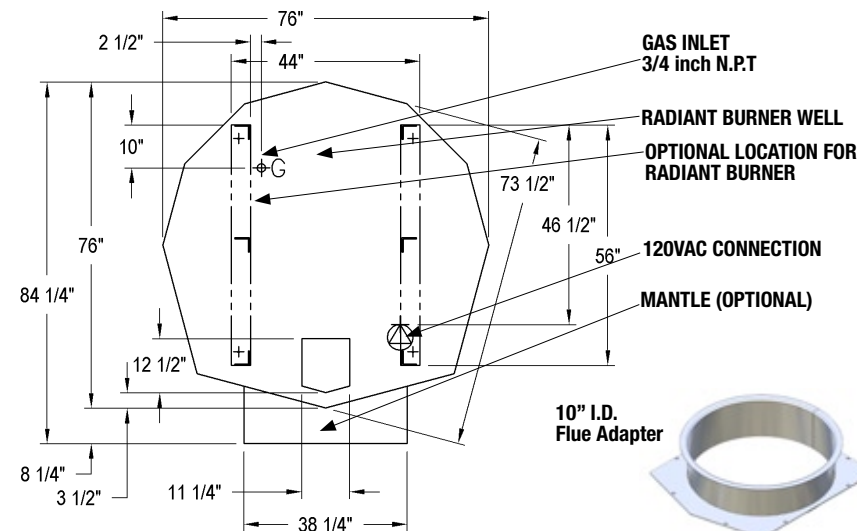

Side View

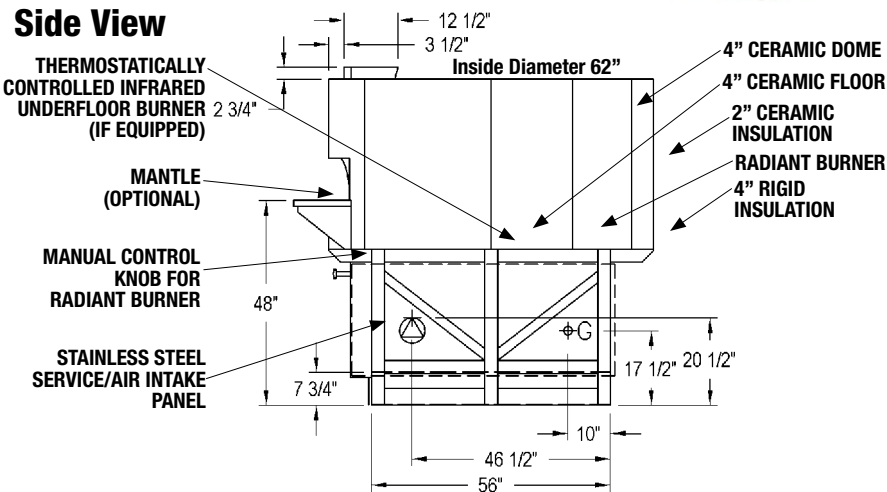

An ongoing program of product improvement may require us to change specifications without notice.
Revised February 2010

WOOD STONE CORPORATION

1801 W. Bakerview Rd.
Bellingham, WA 98226 USA

Toll Free (800) 988-8103

Tel (360) 650-1111

Fax (360) 650-1166

info@woodstone-corp.com or visit www.woodstone-corp.com