

Wood Stone



BISTRO 4343

Dual Burner Stone Hearth Oven



Job Name

Model

WS-BL-4343-RFG-LR

Item#

Fuel Type

Gas-Fired

Hearth Capacity

7" pitas	9
9" pitas	6
8" pizzas	8
10" pizzas	6
12" pizzas	3

OPTIONAL ACCESSORIES

- Stainless Steel Oven Tool Set (with stainless steel hangers)
- Stack-Mounted Exhaust Fan
- Custom Oven Mounted Exhaust Hood

Originally designed as a high production flat bread oven, The Dual Burner Bistro 4343 is also well suited for many other stone hearth cooking applications. The Bistro 4343 features a standard door opening 24 inches wide x 7.5 inches high. The cooking surface is 25 inches wide, and 36 inches deep, resulting in 5.4 square feet of usable deck space.

The dense, high temperature ceramic formulation of which the 450 pound, monolithic, cast-ceramic floor and the 570 pound, monolithic dome are cast creates a "deep heat sink" within the chamber of the oven. The hearth and dome are connected by a carefully tensioned stainless steel exoskeleton, which ensures structural integrity and long life. The oven sits on a heavy-duty frame. A stainless steel storage compartment is optional and can be provided in the support frame.

The ceramic interior is heated by two powerful, independently adjustable radiant burners located on each side of the oven chamber. Each burner is controlled exclusively by the chef, the heat distribution in the oven can be adjusted to meet the needs of a variety of menu items. The Bistro can be configured to burn either Natural Gas or Propane - *gas type should be specified at time of order.*

The oven arrives fully assembled and ready for installation. Optionally, the oven can be shipped crated and ready for on site assembly.

The Bistro vents through a 10 inch O.D. flue collar located above the doorway. Our gas ovens can be direct connected to a power-ventilated, grease-rated chimney or can be vented with a Listed Type 1 exhaust hood or one constructed in accordance with NFPA 96 and all relevant local and national codes. The oven must be vented in accordance with all relevant local and national codes and in a manner acceptable to the authority having jurisdiction.



Wood Stone

An ongoing program of product improvement may require us to change specifications without notice.
Revised January 2008

WOOD STONE CORPORATION

1801 W. Bakerview Rd.
Bellingham, WA 98226 USA

Toll Free (800) 988-8103

Tel (360) 650-1111

Fax (360) 650-1166

info@woodstone-corp.com or visit www.woodstone-corp.com



BISTRO 4343

Dual Burner Stone Hearth Oven

Model

WS-BL-4343-RFG-LR

Front View

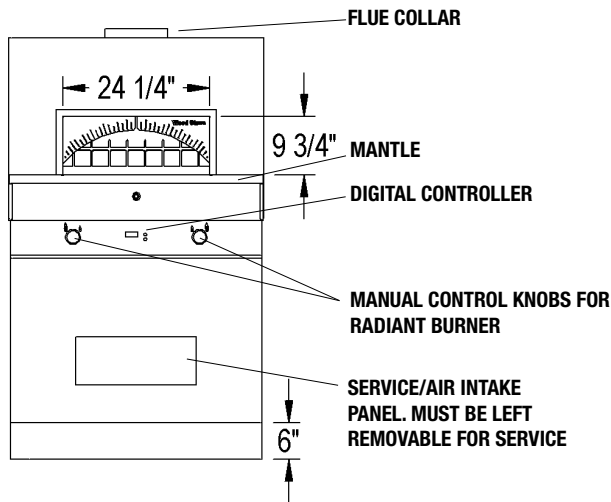

Side View

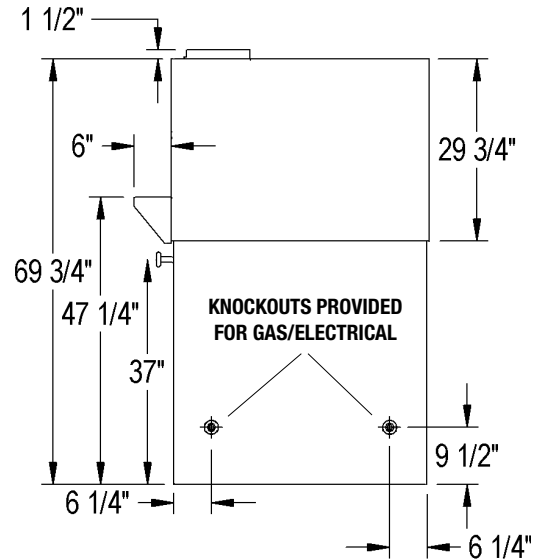

Rear View

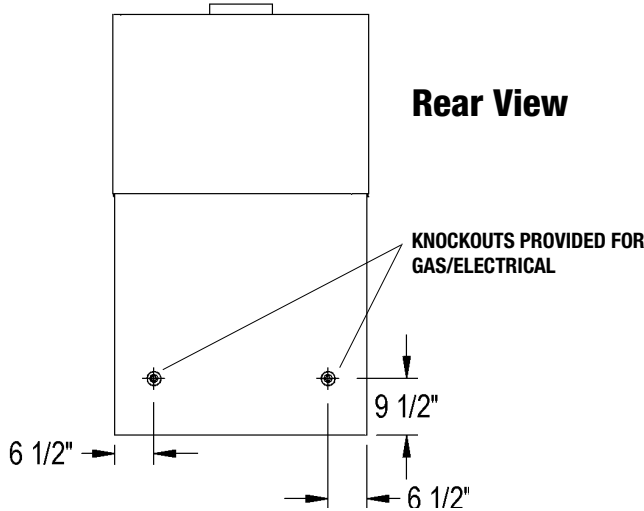

Top View

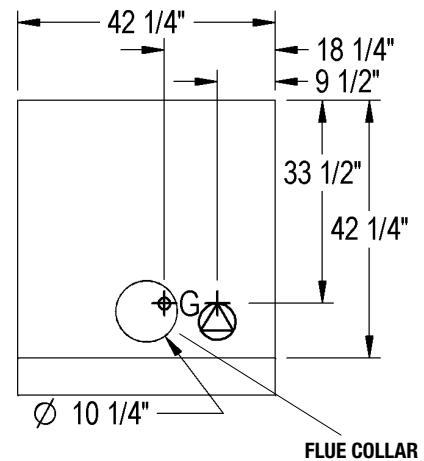

UTILITIES SPECIFICATIONS

Gas-3/4 inch gas inlet (female threaded) ϕ 121,650 BTU/hr

Available configured for propane (LP) or natural gas. Specify gas type when ordering.

**Unit Shipping Weight:
2,050 lbs.**

Electrical

120 VAC, 2 amp, 50/60 Hz ϕ
All utility connections made on the back of the oven control box. Remove front or rear panel for access, use utility knockouts (provided) to route gas and electrical supplies.

VENTING INFORMATION

Our gas ovens are listed for direct venting through a power-ventilated, Listed building heating appliance, also Listed as a grease duct, **OR** through a Listed Type 1 exhaust hood or one constructed in accordance with all relevant local and national codes. This appliance must be vented in accordance with all relevant local and national codes.



An ongoing program of product improvement may require us to change specifications without notice.
Revised January 2008

WOOD STONE CORPORATION

1801 W. Bakerview Rd.
Bellingham, WA 98226 USA

Toll Free (800) 988-8103

Tel (360) 650-1111

Fax (360) 650-1166

info@woodstone-corp.com or visit www.woodstone-corp.com