



CHARCOAL BROILER OVEN

Josper by Wood Stone Charcoal Broiler Oven



Job Name	
Model	WS-CBO-3738
Item#	
Fuel Type	Charcoal-Fired

BROILER OVEN CAPACITY:

The Broiler Oven comes standard with (2) 29.5" x 30" cooking grates, resulting in 885 square inches of cooking area for each grate. The upper grate is typically used for slower cooking items like roasted vegetables, fish and larger roasted meats. The lower grate is used for items requiring extremely intense heat - like steaks and seafood items.

OPTIONAL ACCESSORIES

- Tray Support models available
- Counter-Top models available
- Custom Door and Cabinet Finishes
- Dual Compartment Ash Dolly

The Josper by Wood Stone Charcoal Broiler Oven provides an elegant solid fuel charcoal broiler/oven solution in an oven package and without the venting challenges most often associated with conventional Charcoal Charbroilers.

The unit comes with two adjustable broiler racks that allow the chef to cook a wide variety of meats and vegetables in the oven simultaneously; making this versatile piece of equipment capable of very high production.

By combining the features of an enclosed oven with the traditional characteristics of charbroiled cooking, this piece offers efficiency in utilizing the heat produced by the charcoal. The dual damper system helps minimize charcoal consumption while allowing the unit to maintain high cooking temperatures for extended periods of time, and helps to greatly influence and enhance the flavor profile of the foods being cooked.

The oven sits on a heavy-duty stainless steel cabinet that incorporates an easily removable ash collection system. The unit also ships with an oven mounted firebreak, poker, brush and grill tongs. Other accessories are available.

The Broiler/Oven is ETL Listed with an 18 inch side and 6 inch back clearance to combustible construction.

The Josper by Wood Stone Charcoal Broiler Ovens must be vented with a Listed Type 1 exhaust hood or one constructed in accordance with all relevant local and national codes. The oven must be vented as a solid fuel appliance, and in accordance with all relevant local and national codes, and in a manner acceptable to the authority having jurisdiction. See installation manual for additional information.



An ongoing program of product improvement may require us to change specifications without notice.
Revised April 2010

WOOD STONE CORPORATION
1801 W. Bakerview Rd.
Bellingham, WA 98226 USA

Toll Free (800) 988-8103
Tel (360) 650-1111
Fax (360) 650-1166

info@woodstone-corp.com or visit www.woodstone-corp.com



CHARCOAL BROILER OVEN

Josper by Wood Stone Charcoal Broiler Oven

Model
WS-CBO-3738

Front View

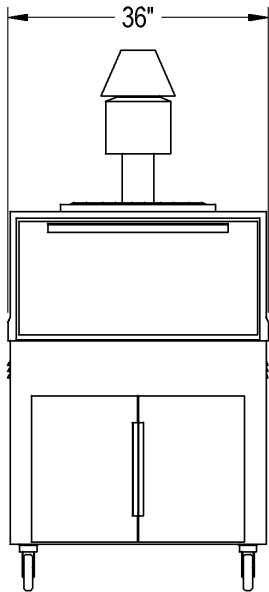

Rear View

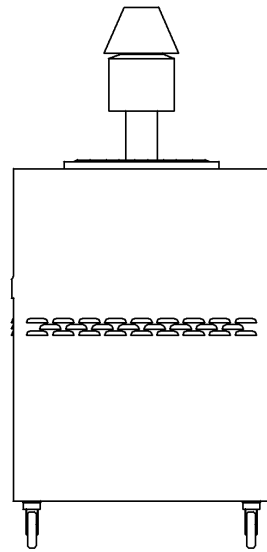

Top View

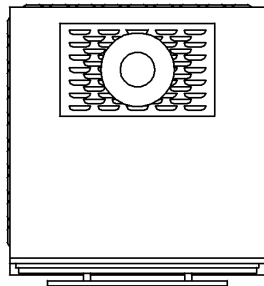

Side View

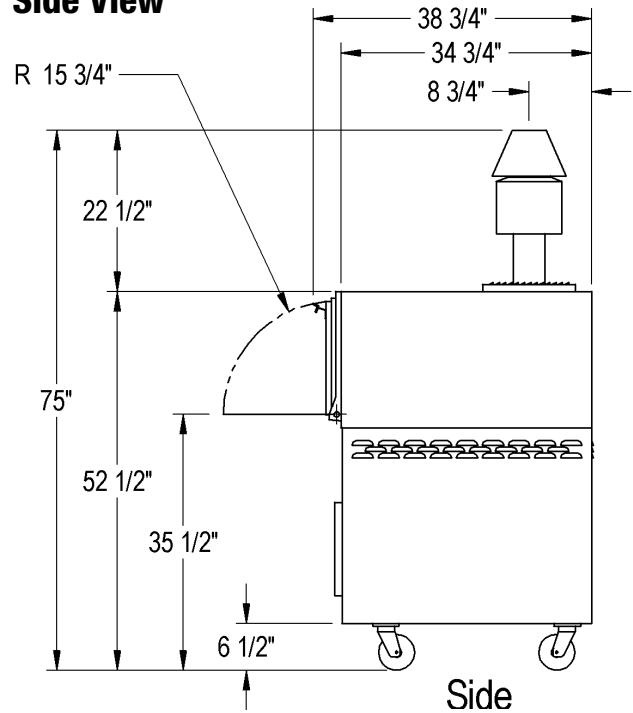

Side

Note: The Wood Stone Josper Charcoal Broiler Oven (WS-CBO) is also available in a 26" x 28" model (WS-CBO-2628) and a 37" x 28" model (WS-CBO-3728), in counter-top and tray support models.

VENTING INFORMATION

The WS-JCO models must be vented using a Listed Type 1 exhaust hood, or one constructed in accordance with NFPA 96 and all relevant local and national codes. The oven must be vented in accordance with all relevant local and national codes, and in a manner acceptable to the authority having jurisdiction.

**Unit Shipping Weight:
approximately 900 lbs.**



An ongoing program of product improvement may require us to change specifications without notice.
Revised April 2010

WOOD STONE CORPORATION
1801 W. Bakerview Rd.
Bellingham, WA 98226 USA

Toll Free (800) 988-8103
Tel (360) 650-1111
Fax (360) 650-1166

info@woodstone-corp.com or visit www.woodstone-corp.com