

Installation and Operation Manual



ROTISSERIES
Single Spit Rotisserie



OKANOGAN
WS-SSR



Wood Stone

WOOD STONE CORPORATION
1801 W. Bakerview Rd.
Bellingham, WA 98226 USA

Toll Free (800) 988-8103
Tel (360) 650-1111
Fax (360) 650-1166

www.woodstone-corp.com
Revised October 2011

This page intentionally left blank >



TABLE OF CONTENTS

THE OKANOGAN	2
INSTALLATION	3
SPIT INSTALLATION	4
OPTIONAL SPITS	5
ELECTRICAL DIAGRAM	6
LIMITED WARRANTY	7



INSTALLATION AND OPERATION MANUAL FOR THE WOOD STONE OKANOGAN ROTISSERIE

**STONE-FIRED COOKING EQUIPMENT
OKANOGAN SINGLE SPIT ROTISSERIE**

WS-SSR-(45, 57)

ADDITIONAL COPIES AVAILABLE UPON REQUEST

Wood Stone's Okanogan Rotisserie has been tested and approved by Intertek Testing Services, and is ETL Listed to ANSI / UL-197, CSA 22.2 and to NSF/ANSI Standard 4.



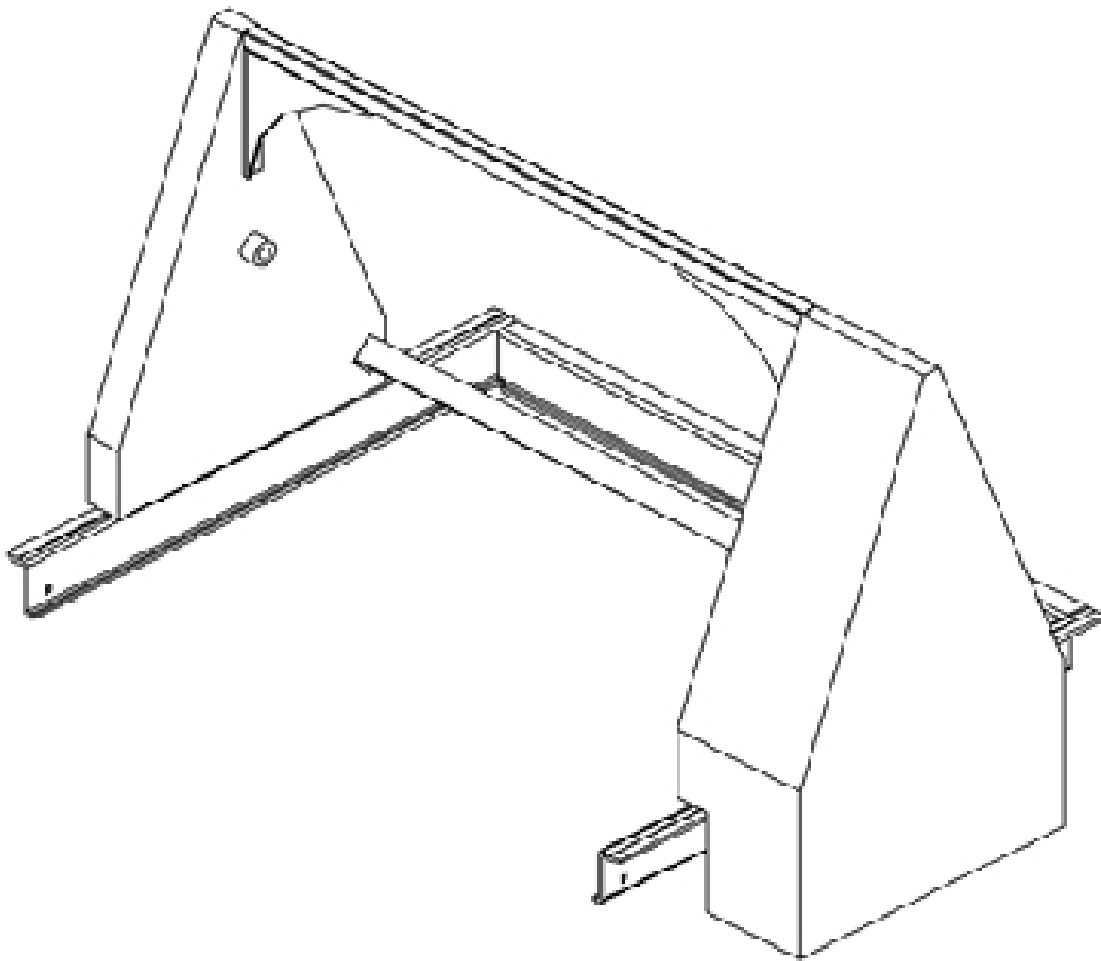

To install the Okanogan rotisserie drive on a Wood Stone charbroiler (if ordered together), simply place the unit on the rails that are at the top of the charbroiler and plug it in. Make sure that the unit glides smoothly on the rails, that the power switch is facing the operator and that the cord and plug are not restricted or in danger of getting too hot.

To install the Okanogan rotisserie drive as an addition to a previously installed Wood Stone charbroiler, the rail/support assembly must first be installed. To do so, place the rail assembly on the charbroiler. The rail/support assembly should seat inside the walls of the charbroiler; make sure the assembly is positioned as far back as it will go. Drill through the walls of the charbroiler as indicated by the holes in the rail assembly. Secure the assembly to the charbroiler using the carriage bolts provided. For the rest of the installation process, refer to the previous paragraph.



- ALWAYS TURN OFF THE MOTOR WHEN LOADING OR UNLOADING THE ROTISSERIE.
- PULL THE OKANOAGAN TOWARD THE FRONT OF THE GRILL TO LOAD AND UNLOAD SPITS.
- USE HOT PADS OR OVEN MITTENS WHEN UNLOADING A SPIT, IT MAY BE VERY HOT!
- ONCE THE SPIT IS SECURELY IN PLACE, PUSH THE ROTISSERIE TOWARD THE BACK OF THE GRILL AND TURN THE MOTOR BACK ON.

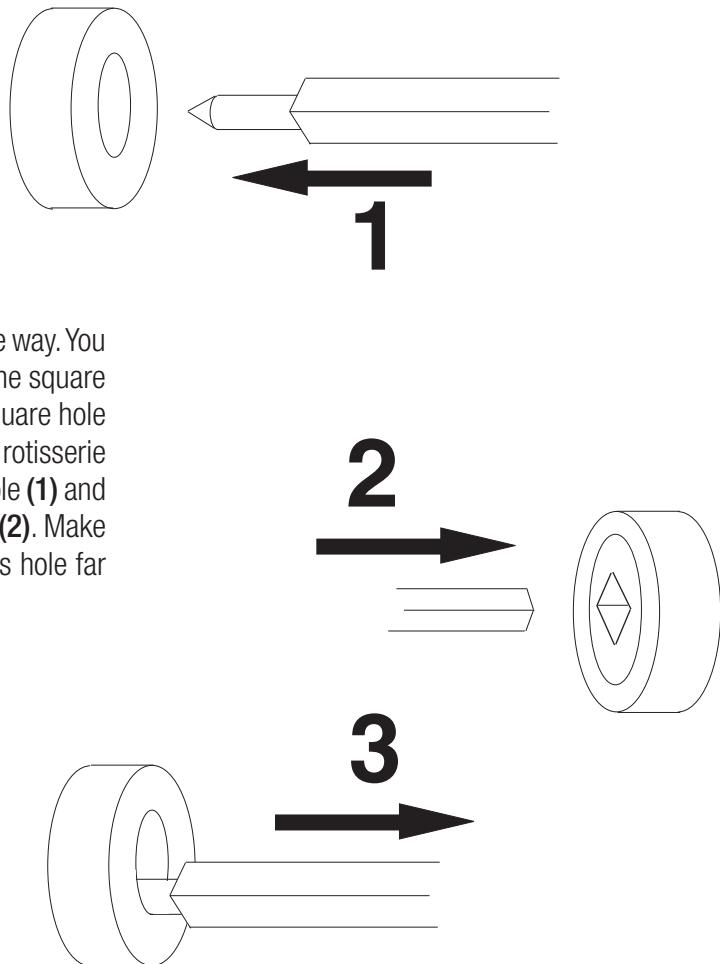

The spits can only be inserted into the rotisserie drive one way. You will notice that all the spits have one pointed end and one square end. The rotisserie drive has one round hole and one square hole (the square hole will always be on the same side as the rotisserie motor). Insert the pointed end of the spit into the round hole (1) and then back the other end of the spit into the square hole (2). Make sure that the pointed end of the spit is backed out of its hole far enough to allow the spit to turn freely (3).



MULTI-SKEWER DRUM SPIT



RIB/FISH BASKET SPIT

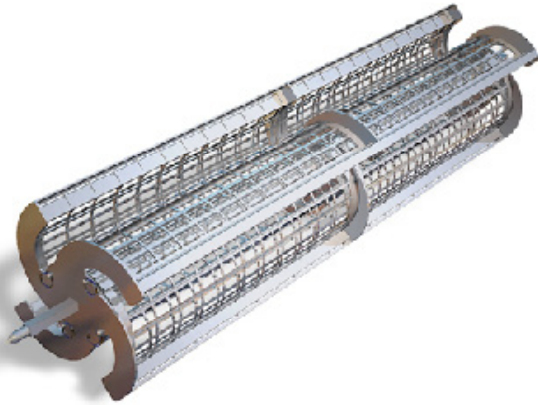

ADJUSTABLE BASKET SPIT

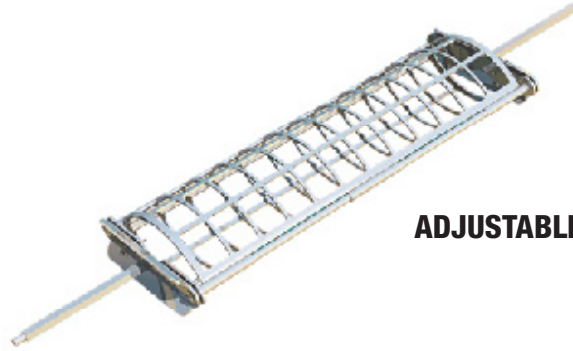

STANDARD ANGLE SPIT

SQUARE SPIT WITH ADJUSTABLE FORKS

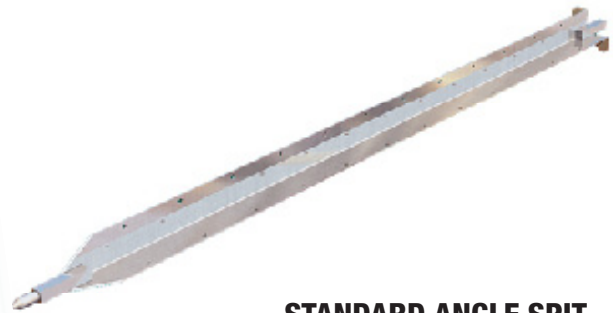
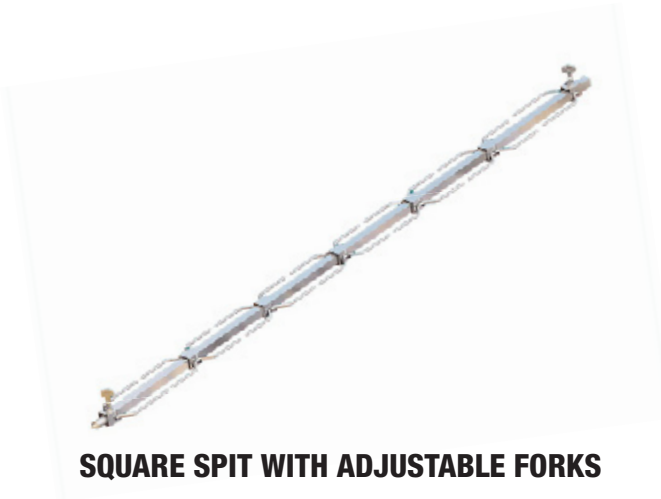

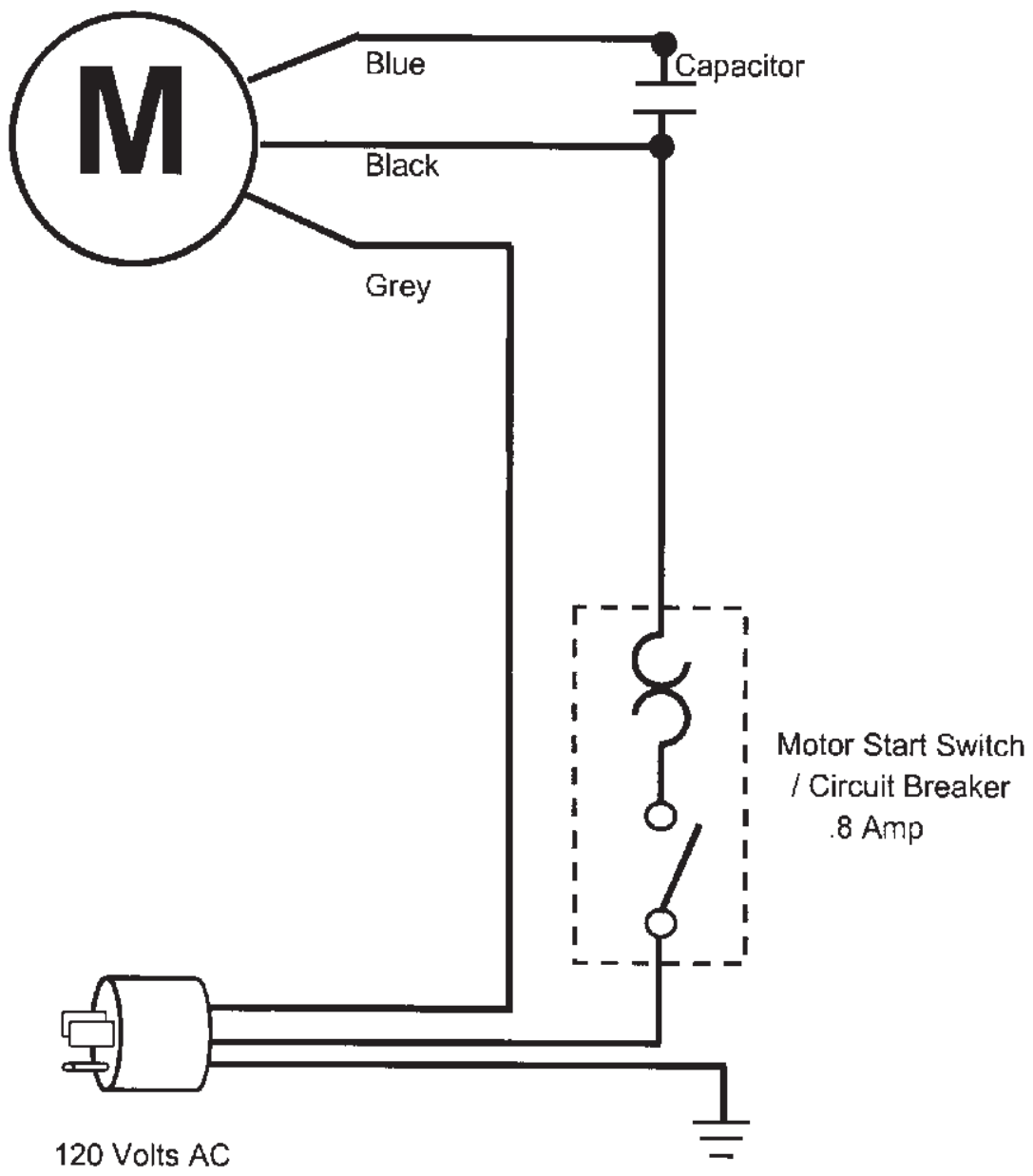



**ALL WARRANTY SERVICE MUST BE PRE-APPROVED BY WOOD STONE
PLEASE CONTACT THE FACTORY FIRST**

Please call 1-800-988-8103 or 1-360-650-1111 seven days a week. Our normal business hours are 8am to 4:30pm Pacific Standard time Monday through Friday. If calling during non-business hours, follow the recorded instructions for emergency service and a Wood Stone technician will get back to you promptly. Wood Stone warrants its equipment to the original purchaser against defects in material or manufacture for a period of one year from the original date of purchase subject to the following exclusions and limitations.

EXCLUSIONS

The warranties provided by Wood Stone do not apply in the following instances:

1. In the event that the equipment is improperly installed. Proper installation is the responsibility of the installer; proper installation procedures are prescribed by the Wood Stone installation manual.
2. In the event the equipment is improperly maintained. Proper maintenance is the responsibility of the user; proper maintenance procedures are prescribed in the Wood Stone installation manual.
3. In the event that the failure or malfunction of the appliance or any part thereof is caused by abnormal use or is otherwise not attributable to defect in material or manufacture.
4. In the event that the appliance, by whatever cause, has been materially altered from the condition in which it left the factory.
5. In the event that the rating plate has been removed, altered or obliterated.
6. On parts that would be normally worn or replaced under normal conditions.
7. Normal cracking due to expansion and contraction stress relief in either the dome or oven deck.
- 8. In the event that pressed log products of any type have been burned in the equipment.**
9. Damage resulting from the use of chemical cleaning products in the oven, as well as any damage from liquids or chemicals being poured or sprayed into the oven.

If any oral statements have been made regarding this appliance, such statements do not constitute warranties and are not part of the contract of sale. This Limited Warranty constitutes the complete, final and exclusive statement with regard to warranties.

THIS LIMITED WARRANTY IS EXCLUSIVE AND IN LIEU OF ALL OTHER WARRANTIES WHETHER WRITTEN, ORAL OR IMPLIED, INCLUDING, BUT NOT LIMITED TO, ANY WARRANTY OF MERCHANTABILITY OR FITNESS FOR PARTICULAR PURPOSE OR WARRANTY AGAINST LATENT DEFECTS

LIMITATIONS OF LIABILITY:

In the event of warranty claim or otherwise, the sole obligation of Wood Stone shall be the repair and/or replacement, at the option of Wood Stone, of the appliance or component or part thereof. Such repair or replacement shall be at the expense of Wood Stone with the exception of travel over 100 miles or two hours, overtime, and holiday charges which shall be at the expense of the purchaser. Any repair or replacement under this warranty does not constitute an extension of the original warranty for any period of the appliance or for any component or part thereof. Parts to be replaced under this warranty will be repaired or replaced at the option of Wood Stone with new or functionally operative parts. The liability of Wood Stone on any claim of any kind, including claims based on warranty, expressed or implied, contract, negligence, strict liability or any other theories shall be solely and exclusively the repair or replacement of the product as stated herein, and such liability shall not include, and purchaser specifically renounces any rights to recover, special, incidental, consequential or other damages of any kind whatsoever, including, but not limited to, injuries to persons or damage to property, loss of profits or anticipated profits, or loss of use of the product.

TO SECURE WARRANTY SERVICE:

If you claim a defect covered by this Limited Warranty, direct your claim to:
Wood Stone Corporation 1801 W. Bakerview Rd. Bellingham, WA 98226 USA Attn: National Service Manager