



# INSTALLATION AND OPERATION MANUAL

FOR

## Wood Stone

WS-MS-(4,5,6,7)-(RFG-IR, RFG)-CE-(NG,LP)

European Model Natural Gas or Liquid Propane Fueled Stone Hearth Ovens



This appliance is for professional use by qualified personnel. This appliance must be installed by qualified persons in accordance with the regulations in force. This appliance must be installed with sufficient ventilation to prevent the occurrence of unacceptable concentrations of substances harmful to health in the room in which it is installed. This appliance needs an unobstructed flow of fresh air for satisfactory combustion and must be installed in a suitably ventilated room in accordance with current regulations. This appliance should be serviced by qualified personnel at least every 12 months, or sooner if heavy use is expected.

**Wood Stone Corporation**

1801 W. Bakerview Rd.

Bellingham, WA 98226 - USA

Tel. 1-360-650-1111 Fx. 1-360-650-1166

Email - [info@woodstone.net](mailto:info@woodstone.net)

Website - [www.woodstone-corp.com](http://www.woodstone-corp.com)

### LIFTING THE OVEN

#### 1. USING A CRANE

The oven arrives with four lifting eyes attached. When craning a Wood Stone oven, use a spreader bar with a two-legged sling rigged on each end. The spreader bar should be of a sufficient length to keep the sling from contacting the oven.

**NOTE:** Once lifting eyes are no longer needed, remove the lifting eyes one at a time AND **BE SURE TO REPLACE THE BOLTS** THAT ATTACH THE OVEN TO THE STAND.

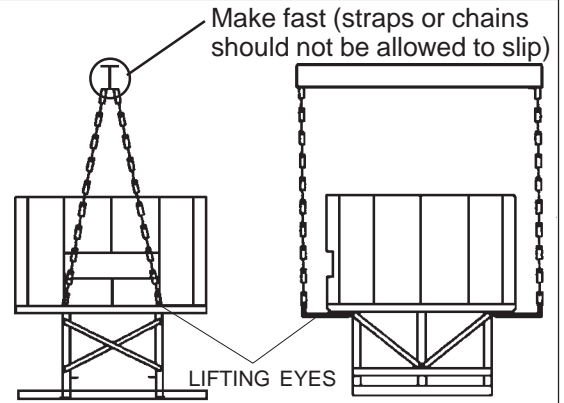

#### 2. USING A FORKLIFT

Be sure to use a forklift rated to lift more than the oven weighs. Fork length must be at least 1.8 m, if not, fork extensions should be used. The oven stand is equipped with fork pockets just above the angle iron base. *The oven is very top heavy* so spread the forks as far apart as possible.

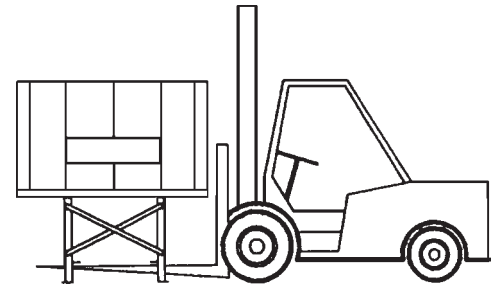

| Model # | Oven          | Approx. Weight | Req'd Forklift |
|---------|---------------|----------------|----------------|
| WS-MS-4 | Mt. Chuckanut | 1,000 Kg       | 2,000 Kg       |
| WS-MS-5 | Mt. Adams     | 1,500 Kg       | 3,000 Kg       |
| WS-MS-6 | Mt. Baker     | 1,900 Kg       | 3,000 Kg       |
| WS-MS-7 | Mt. Rainier   | 2,400 Kg       | 4,000 Kg       |

#### USING A PALLET JACK TO MOVE A WOOD STONE OVEN

Once the oven has been removed from the delivery vehicle, it can easily be moved on flat surfaces using a pallet jack. To lift the oven with a pallet jack, remove the front and rear angle iron stabilizers from the base of the oven stand and place two or three stout 4x4 posts through the fork pockets. **THE OVEN IS VERY TOP-HEAVY, MOVING THE OVEN UP OR DOWN A RAMP ON A PALLET JACK IS NOT SAFE!**

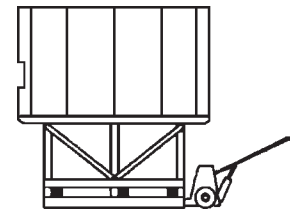

## **DO NOT TURN THE OVEN ON ITS SIDE!**

Moving a Wood Stone oven can present interesting challenges to even the most experienced riggers. Secure the proper equipment and make safety your first priority. Please don't hesitate to call the factory for technical support (360-650-1111).

IF THIS OVEN IS NOT PROPERLY INSTALLED A FIRE MAY RESULT. TO REDUCE THE RISK OF FIRE, FOLLOW THESE INSTALLATION INSTRUCTIONS. A MAJOR CAUSE OF OVEN RELATED FIRES IS FAILURE TO MAINTAIN REQUIRED CLEARANCES (AIR SPACES) TO COMBUSTIBLE MATERIALS. IT IS OF UTMOST IMPORTANCE THAT THIS OVEN BE INSTALLED ONLY IN ACCORDANCE WITH THESE INSTRUCTIONS.



**WARNING:** Installation and servicing of this product could expose you to glasswool/ceramic fibers as well as Calcium Silicate dust. **ALWAYS WEAR RESPIRATORY AND EYE PROTECTION WHEN INSTALLING OR SERVICING THIS APPLIANCE.** Please read this entire manual before you install the oven. Failure to follow instructions may result in property damage, bodily injury or even death. Contact your local building or fire officials about restrictions and installation inspection in your area.

## **CLEARANCES**

a. Wood Stone gas-fired oven should have a **minimum 25 mm clearance to combustibles from all sides, and 355 mm clearance to combustibles from the top** (See Figure on page 4).

If building a facade that will contact the oven, use completely non-combustible materials\*. Please note that standard drywall (or sheet rock) is considered a combustible.

b. Any facade above and/or 50 mm to either side of the oven doorway, must be constructed of noncombustible building materials. (See page 4).

c. Install this oven only on noncombustible floors.

*\*When noncombustible building materials contact the body of the oven, the respective clearances are transferred to those non-combustibles.*

- — — Upon installation, the oven must maintain at least a 25 mm side clearance to any and all combustible building materials
- Upon installation, the oven must maintain at least a 360 mm top clearance to any and all combustible building materials
- ■ ■ Maintain proper clearances to combustible building materials as specified by pertinent codes and/or the hood manufacturer's recommendations

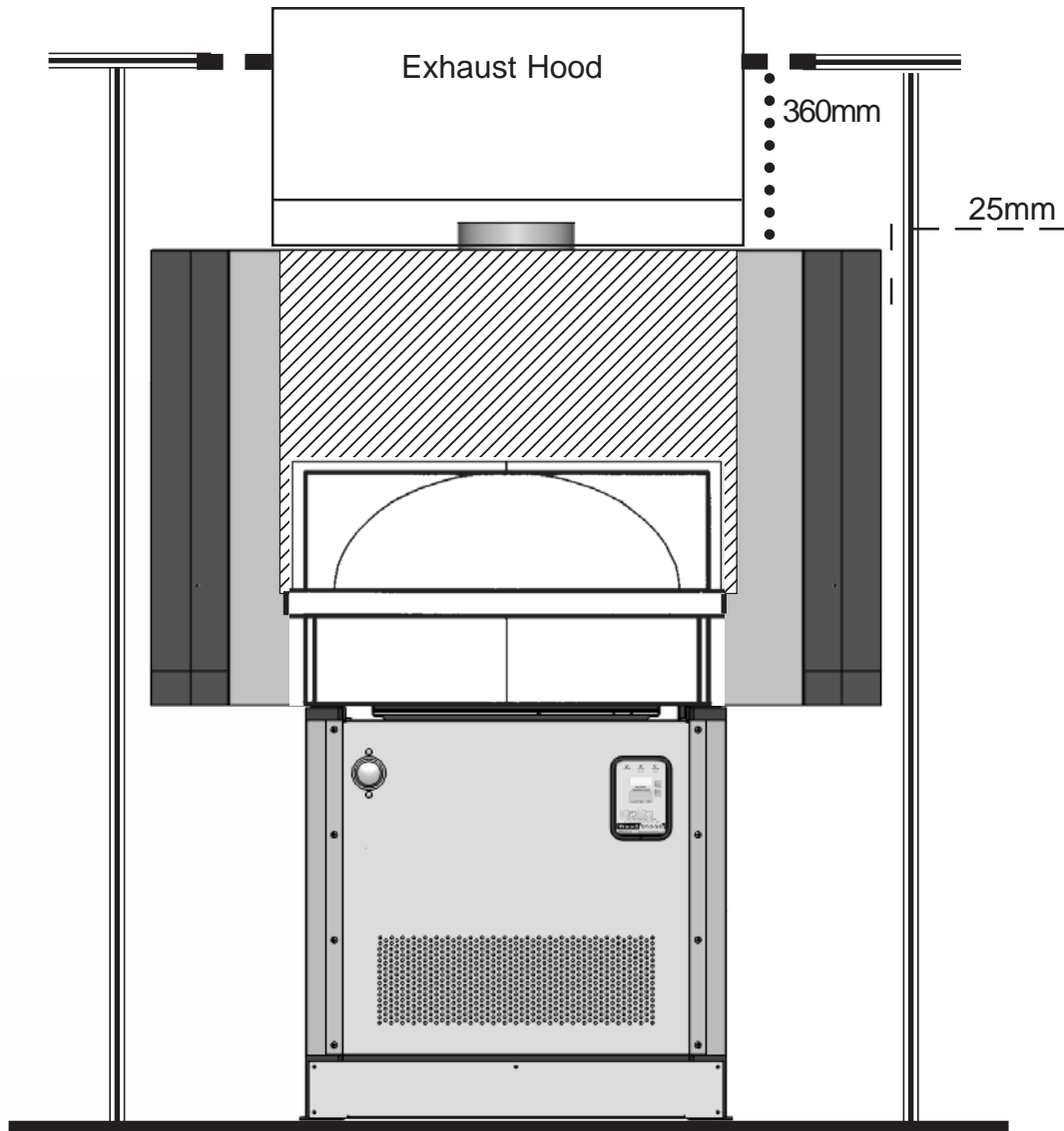

Install only on a non-combustible floor or provide a non-combustible floor covering under the oven, which extends 920 mm to the front of and to both sides of the oven's doorway opening.

- ==== Combustible
- Noncombustible

## ASSEMBLY

1. Mount the oven mantle (if provided) directly below the doorway and flush with the floor using the hardware provided (See page 6 for details).
2. Mount the stainless steel toe kick to the front of the oven stand, near the floor using the hardware provided (See page 7).
3. Mount the service/intake panel to the brackets on the front of the stand, directly below the doorway, using the hardware provided (See page 7).
  - a. Do not obstruct the flow of combustion and ventilation air between the toe kick and the bottom of the service/intake panel.
  - b. This panel is the only access for servicing the gas and electrical components of the oven so it must be left accessible and removable.

Whether mounting a stainless mantle or a bracket for a granite mantle, the initial steps are the same.

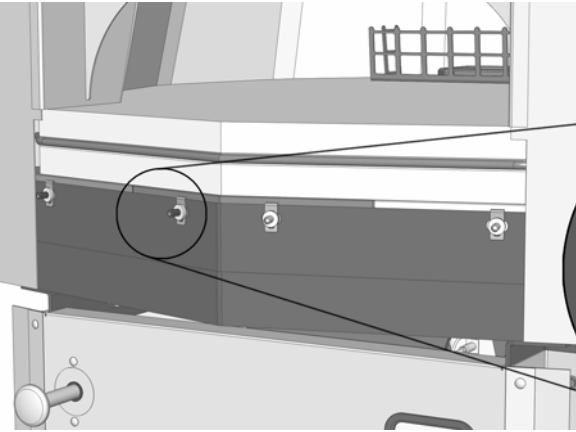

1. Begin by installing the threaded studs into the clip nuts below the oven doorway (3 or 4 turns is sufficient).

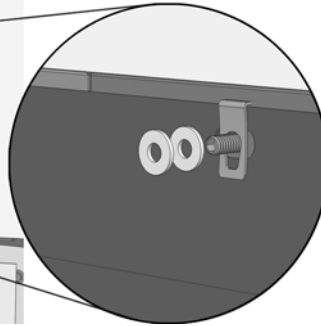

2. Next, place two spacer washers on each stud.

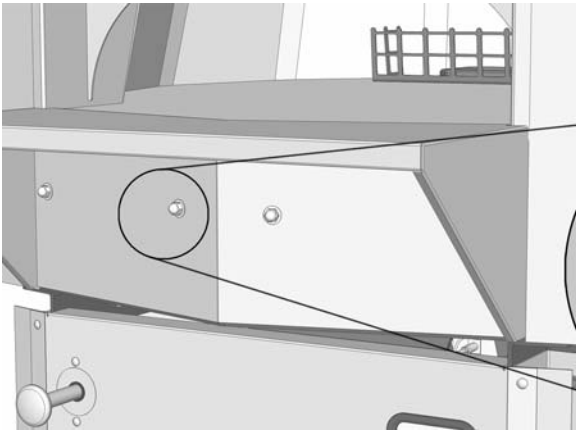

3. Position the mantle (or bracket) on the oven, making sure that the rear flange rests on the floor of the oven (you may need an extra pair of hands at this point).

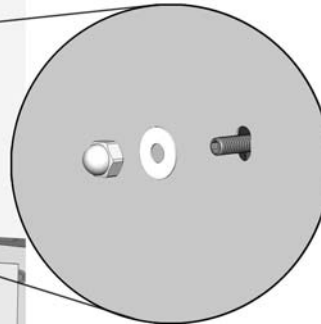

4. Lastly, place one final washer (stainless steel) and a cap nut on each stud. Tighten the cap nuts so that the mantle is securely held in place.

5. Using the high temperature silicone (provided), fill any gaps between the oven hearth and the mantle flange. Gaps between the mantle flange and the stainless steel doorway frame may also need to be filled with a small amount of the silicone compound.

**INSTALLATION OF GRANITE** - After completing the steps outlined above, apply a generous amount of silicone adhesive (provided) to the top of the steel mantle bracket.

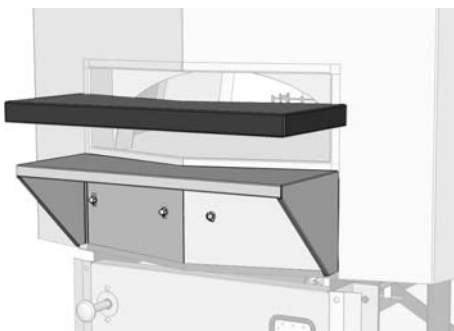

Put the stone in place and apply light pressure to seat it properly. Make sure that the angle in the granite lines up with the angle in the bracket. Allow the adhesive to set for several hours before filling any gap between the stone slab and the metal bracket with the silicone compound (provided). Clean up any adhesive and/or silicone before it dries!

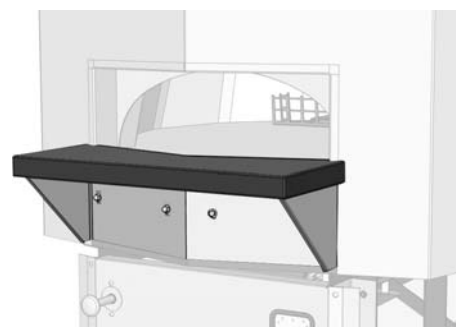

## Standard Front Panel and Toe Kick

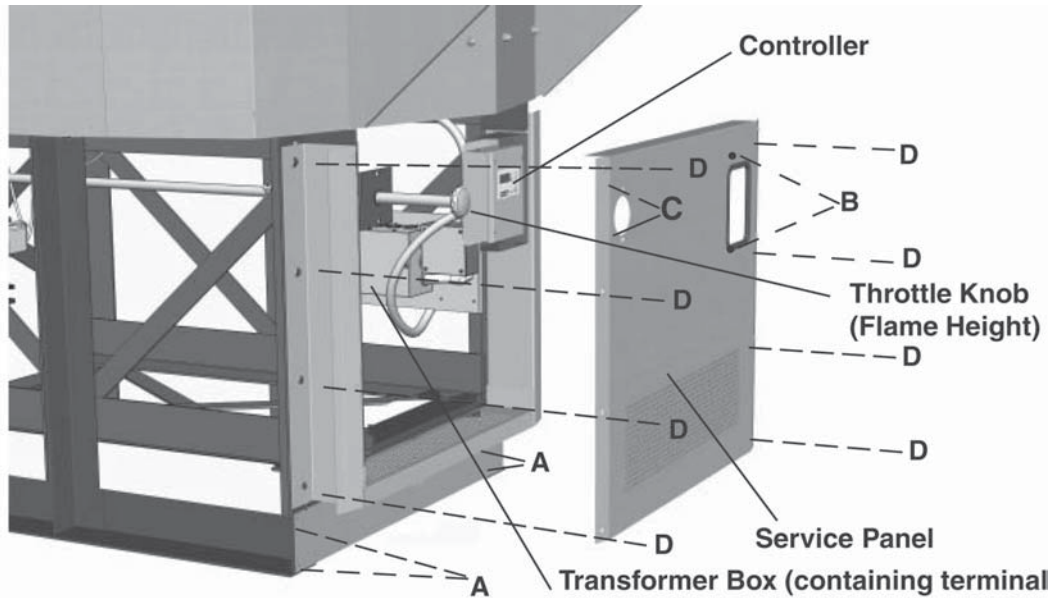

**Transformer Box (containing terminal strip for incoming power supply).**

NOTE: Have a licensed electrician make the electrical connection here.



**A - Hex-head self-tapping screw - to attach toe kick. 4 total.**



**C - Phillips head #10 screw - Attaches service panel to throttle knob bracket. 2 total.**



**B - Phillips head 1/4-20 screw - Attaches service panel to controller bracket. 2 total.**



**D - Phillips-head self-tapping screw-used to secure the sides of the service panel. 8 total.**

### View of Throttle Assembly

The throttle knob position can be adjusted inward or outward by loosening the clamp and sliding the throttle knob assembly to the desired position. Be sure to retighten the clamp once the throttle knob is in the desired position.

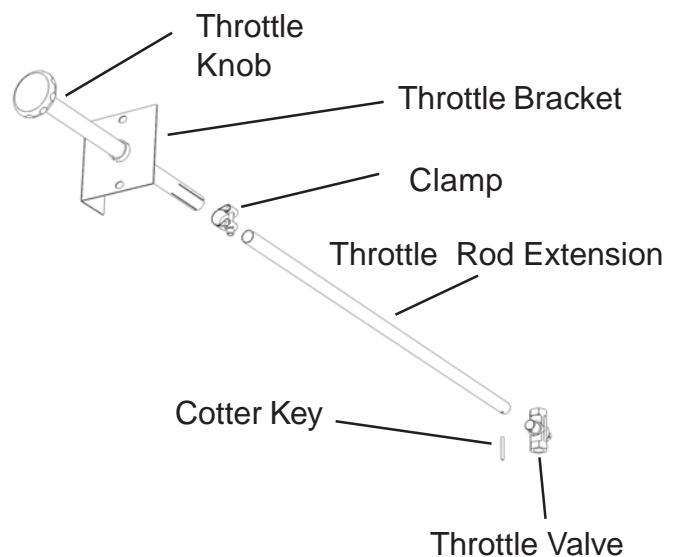

## GAS

Wood Stone Gas ovens are equipped with a 3/4" female ISO-7 gas connection. **Have a licensed gas installer provide the hookup and test all fittings and pipe connections for leaks.** Use approved gas leak detectors (soap solutions or equivalent) over and around the fittings and pipe connections.



**DO NOT USE FLAME TO TEST FOR LEAKS!**

SV-1 and SV-2 are the gas control valves that operate under floor infrared burner and the interior radiant burner, respectively. **NOTE: RFG models are only equipped with the SV-2 valve.** SV-1 is located directly behind the service/ intake panel and in front of the under floor infrared burner. SV-2 is located under the oven to the rear left.

**The manifold pressure test port for the infrared under floor burner (served by SV-1) is a plugged nipple tap located near the left end of the burner manifold. The manifold pressure test port for the radiant burner (served by SV-2) is a plugged nipple tap located at the base of the T-junction between the SV-2 and the radiant/interior burner. Both gas valves (SV-1 and SV-2) have an additional plugged nipple tap on the inlet side.** The burner manifold pressures have been adjusted and tested at the factory.

**Wood Stone recommends that the oven be equipped with an individual shutoff valve and that this individual shutoff valve (supplied by others) be left easily accessible. Wood Stone also recommends that inspection and maintenance of the burners and gas piping connections of this appliance be performed at regularly scheduled intervals and only by professional gas appliance service agencies.**

### Scope of Approvals

I<sub>2H</sub> at 20 mbar for use in AT, DK, ES, FI, IE, IT, PT, GB, SE, CH

I<sub>2E</sub> at 25 mbar for use in DE

I<sub>2L</sub> at 25 mbar for use in NL

I<sub>3+</sub> (28-30/37/50) for use in BE, ES, FR, IE, IT, PT, GB, CH

I<sub>3B/P</sub> (28-30/37/50) for use in SE, CH, AT, DK, FI, DE, NL, NO, FR

I<sub>3P</sub> (30/37/50) for use in DE, ES, FR, IE, NL, PT, GB, CH

## ELECTRICAL

**Have a licensed electrician wire the transformer terminal strip with a 230Volt, 5 amp lead.** Electrical diagrams are located on the back of the removable service/air intake panel of the appliance and also at the end of this manual. See page 7 of this manual for location of the transformer enclosure.



**ELECTRICAL GROUNDING:** This appliance must be electrically grounded.

**PROVIDE DISCONNECT DEVICE:** This appliance must be provided with an all-pole type disconnect device in the incoming power supply so that the appliance can be completely isolated from the power supply.

| EN 437 Gas group      | I <sub>2H</sub> | I <sub>2E</sub> and I <sub>2L</sub> | I <sub>3+</sub> | I <sub>3B/P(30)</sub> | I <sub>B/P(50)</sub> | I <sub>3P</sub> |
|-----------------------|-----------------|-------------------------------------|-----------------|-----------------------|----------------------|-----------------|
| Inlet Pressure (mbar) | 20              | 25                                  | 28-30/37/50     | 30                    | 50                   | 30/37/50        |

|                   | Declared Input (kW)                                   |                              |                          |                           |
|-------------------|---|------------------------------|--------------------------|---------------------------|
|                   | I <sub>2H</sub> , I <sub>2L</sub> and I <sub>2E</sub> | I <sub>3+(28-30/37/50)</sub> | I <sub>3B/P(30-50)</sub> | I <sub>3P(30/37/50)</sub> |
| WS-MS-4-RFG-CE    | 20  | 17.6                         | 17.6                     | 17.6                      |
| WS-MS-4-RFG-IR-CE | 33.7  | 29.9                         | 29.9                     | 29.9                      |
| WS-MS-5-RFG-CE    | 30.8  | 27.5                         | 27.5                     | 27.5                      |
| WS-MS-5-RFG-IR-CE | 55.1  | 46.6                         | 46.6                     | 46.6                      |
| WS-MS-6-RFG-CE    | 30.8  | 27.5                         | 27.5                     | 27.5                      |
| WS-MS-6-RFG-IR-CE | 55.1  | 46.6                         | 46.6                     | 46.6                      |
| WS-MS-7-RFG-CE    | 36  | 36                           | 36                       | 36                        |
| WS-MS-7-RFG-IR-CE | 64.5  | 66.5                         | 66.5                     | 66.5                      |

|                   | Valve Outlet Pressures (mbar)                         |      |                              |      |                          |      |                           |      |
|-------------------|---|------|------------------------------|------|--------------------------|------|---------------------------|------|
|                   | I <sub>2H</sub> , I <sub>2E</sub> and I <sub>2L</sub> |      | I <sub>3+(28-30/37/50)</sub> |      | I <sub>3B/P(30-50)</sub> |      | I <sub>3P(30/37/50)</sub> |      |
|                   | SV-1  | SV-2 | SV-1                         | SV-2 | SV-1                     | SV-2 | SV-1                      | SV-2 |
| WS-MS-4-RFG-CE    |   | 12.4 |                              | 13.6 |                          | 13.6 |                           | 17.4 |
| WS-MS-4-RFG-IR-CE | 8.7   | 12.4 | 17.5                         | 13.6 | 17.5                     | 13.6 | 22.4                      | 17.4 |
| WS-MS-5-RFG-CE    |   | 11.8 |                              | 15.6 |                          | 15.6 |                           | 20   |
| WS-MS-5-RFG-IR-CE | 8.7   | 11.8 | 17.5                         | 15.6 | 17.5                     | 15.6 | 22.4                      | 20   |
| WS-MS-6-RFG-CE    |   | 11.8 |                              | 15.6 |                          | 15.6 |                           | 20   |
| WS-MS-6-RFG-IR-CE | 8.7   | 11.8 | 17.5                         | 15.6 | 17.5                     | 15.6 | 22.4                      | 20   |
| WS-MS-7-RFG-CE    |   | 11.8 |                              | 18.4 |                          | 18.4 |                           | 23.6 |
| WS-MS-7-RFG-IR-CE | 8.7   | 11.8 | 17.9                         | 18.4 | 17.9                     | 18.4 | 22.9                      | 23.6 |

Wood Stone ovens should be vented in accordance with pertinent national, regional and local codes concerning such appliances; check venting plans with the authority having jurisdiction *before* proceeding with installation.

The above statement taking precedence, Wood Stone Corporation recommends the following:

The Wood Stone MS Series ovens can be vented as a **Type A** appliance (with no flue connection), designed to be installed under an exhaust hood.

It is also approved as a **Type B<sub>1</sub>** appliance, designed to be connected to a chimney which is installed in accordance with all relevant local and national codes.

This page illustrates and describes proper specifications and installation for exhaust hoods used to vent Wood Stone ovens. These hoods are available from Wood Stone; contact your equipment supplier for ordering.

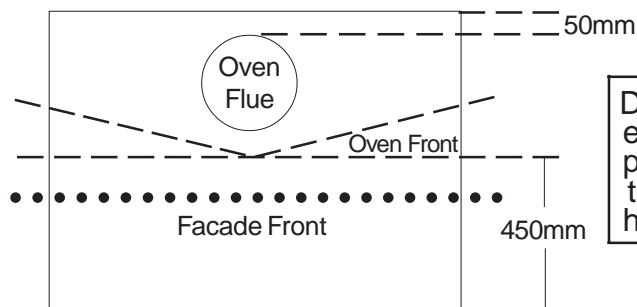
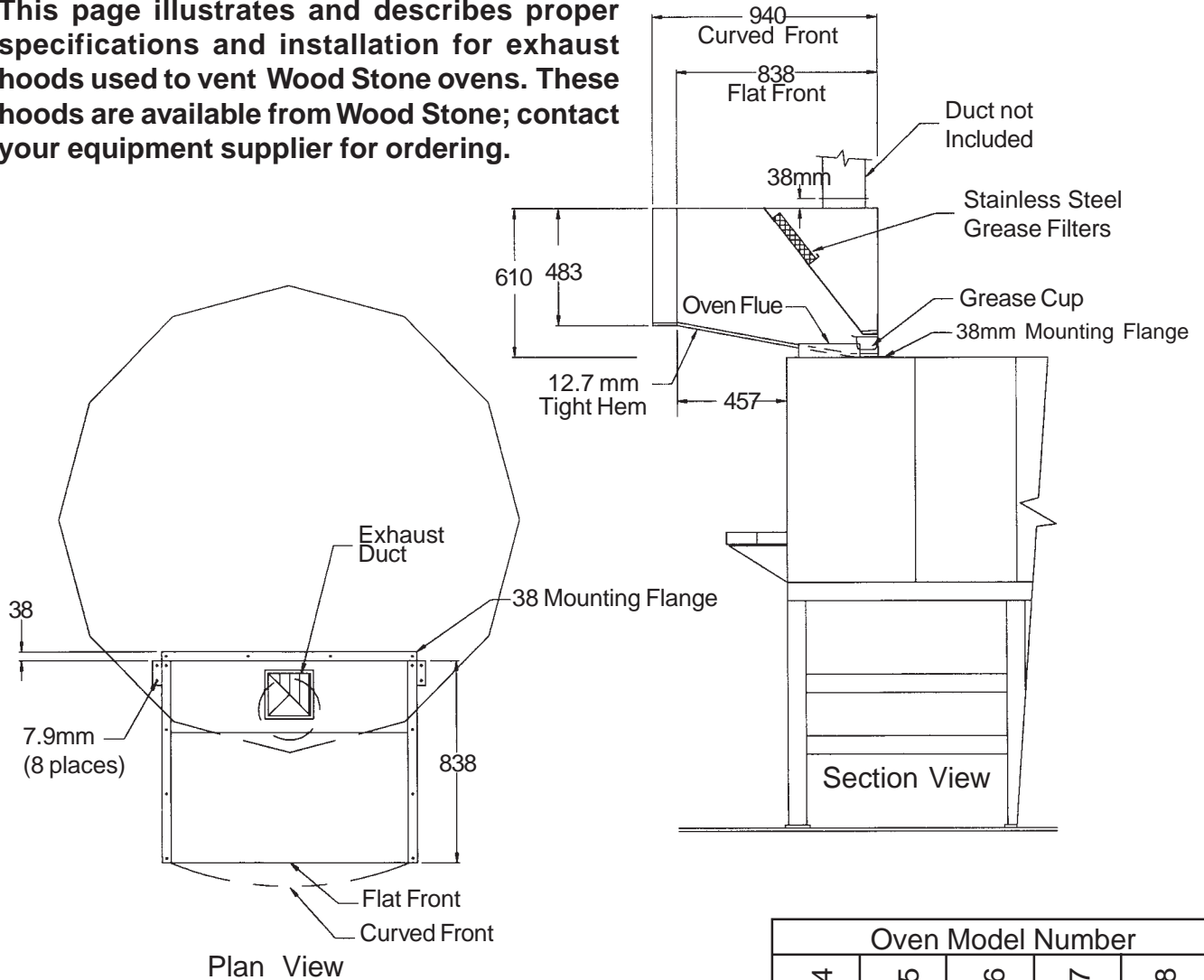

NOTE: The recommended front overhang of 450 mm is achieved by installing so that the inside-back of the hood is 50 mm from the back of the oven flue collar. **The hood should overhang the front of all facades by at least 200 mm to allow removal and cleaning of filters.**

|                              | Oven Model Number |             |             |             |             |
|------------------------------|-------------------|-------------|-------------|-------------|-------------|
|                              | WS-MS-4           | WS-MS-5     | WS-MS-6     | WS-MS-7     | WS-MS-8     |
| Width                        | 762mm             | 1067mm      | 1067mm      | 1219mm      | 1600mm      |
| Depth                        | Flat Front        | 838mm       | 838mm       | 838mm       | 838mm       |
|                              | Curved Front      | 940mm       | 940mm       | 940mm       | 940mm       |
| Required m <sup>3</sup> /min | 12.7              | 17.7        | 17.7        | 19.8        | 26.1        |
| Duct Size                    | 152 x 152mm       | 178 x 178mm | 178 x 178mm | 190 x 190mm | 216 x 216mm |
| Static Press. mmHg           | -1.5              | -1.5        | -1.5        | -1.5        | -1.5        |
| Weight in Kg                 | 60                | 80          | 80          | 90          | 135         |

## INITIAL OVEN STARTUP (RFG-IR)

see page 16 for RFG models

### FIRST DAY

1. Make sure main gas supply is on (valve parallel with gas line).
2. **Push I/O button on controller.** It may take a while for the gas to purge all the air from the gas lines.
3. Allow oven to operate at **FACTORY SETTINGS** for 1 hour (thermostat set at 93 degrees, radiant flame at its lowest setting).
4. After one hour, raise dome flame to 25% (~16 cm flame), hold this setting for 4 hours.
5. After 4 hours @ 25% flame, raise to 50% flame and hold for at least another 4 hours.  
The oven can be left at this setting all night.

### SECOND DAY

1. Set the floor temperature to 260 degrees C.
2. Turn the radiant flame to 75% height.  
*The floor temperature should reach 260 degrees C within about an hour. The oven is now ready for cooking, go to it!!*

## General Daily Oven Operation

### END OF THE DAY

1. Push I/O button, all gas will go off, *even the pilots.*
2. Put oven door in place to retain heat.

### BEGINNING OF THE DAY

1. Remove oven door
2. Push I/O button, set controller to desired floor temperature and turn the radiant flame to its highest setting. *Oven should be stabilized at or above the set point within an hour.*

### CLEANING THE OVEN

1. As needed (twice per hour), use the floor brush to sweep stray food debris to the doorway, where it can be easily removed with a dough cutter or spatula.
2. As needed, swab the deck using a damp (not wet) rag wrapped around the floor brush.



**NEVER PLACE ANYTHING IN OR ABOVE THE RADIANT FLAME**

### HOW TO READ FLOOR TEMPERATURE



The floor temperature is continuously displayed by the controller in the upper window. This reading is being taken by a thermocouple about an inch below the floor surface, so the actual surface temperature may be somewhat different, and is best measured using a non-contact (IR) thermometer.

### HOW TO ADJUST THE FLOOR TEMPERATURE (SET POINT)



To adjust the oven's thermostatic floor temperature setting, simply press the arrow button corresponding to the direction in which you would like the setting to go. If the thermostatic set point is raised above the actual hearth temperature, the underfloor burner should activate.

## DETAILED DAILY OVEN OPERATION

### for RFG-IR models only

See page 17 for RFG models



**IMPORTANT:** *If at any time you feel that either or both of the burners are not operating properly, TURN THE OVEN OFF and call for service. Before servicing, disconnect the electrical supply at the breaker and turn off the gas supply at the appliance's individual gas shutoff valve. In the event of a power failure, no attempt should be made to operate the oven.*

#### 1. DAILY STARTUP

**Press the I/O button to start the oven.**

The Radiant Flame will ignite. The infrared under floor burner will ignite if the actual floor temperature is below the set point temperature to which the controller is adjusted.

 **GREEN LIGHT:** indicates the system is energized.

 **GREEN LIGHT:** indicates the pilot flame for the radiant burner is lit.

 **GREEN LIGHT:** indicates that the pilot flame for the infrared (under-floor) burner is lit. This light will go off whenever the actual floor temperature is above the thermostatic set point.

#### 2. TURNING OFF THE OVEN

**Push the I/O button on the controller to turn the oven off.**

Both burners will go out and the digital readout on the controller will go out.

#### 3. ADJUSTING THE RADIANT (dome) FLAME

**To adjust the radiant flame:** The radiant flame is always on (when the oven is operating) and can be adjusted to any flame intensity between its highest and lowest setting. Simply turn the knob located to the lower left of the doorway, beneath the mantle. This burner is the primary heat source for the oven. The infrared under floor burner will act as an assist, to maintain desired floor temperatures during periods of high food production.

#### 4. ADJUSTING THE FLOOR SET-POINT



To adjust the oven's thermostatic floor temperature setting, simply press the arrow button corresponding to the direction in which you would like the setting to go. If the thermostatic set point is raised above the actual hearth temperature, the underfloor burner should activate.

\* *It is only possible to program the floor's thermostatic hearth set point to temperatures from 93 degrees C to 371 degrees C. Once proper temperatures for your application have been established, there should be little or no need to change the hearth set point.*



**STAINLESS STEEL DOORS:** The door(s) are used for nighttime heat retention.  
**Do not operate the oven with doors in place.**

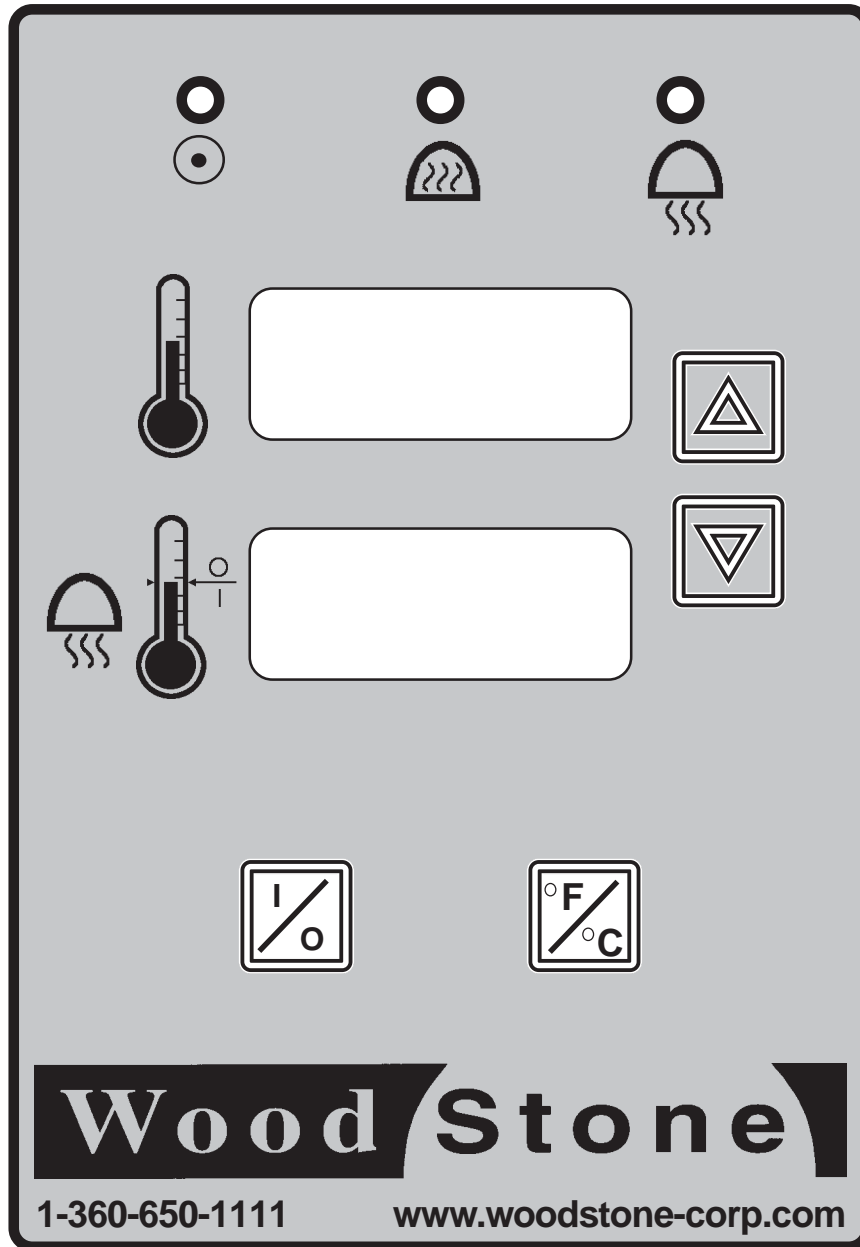

NOTE: see page 15 for RFG controller

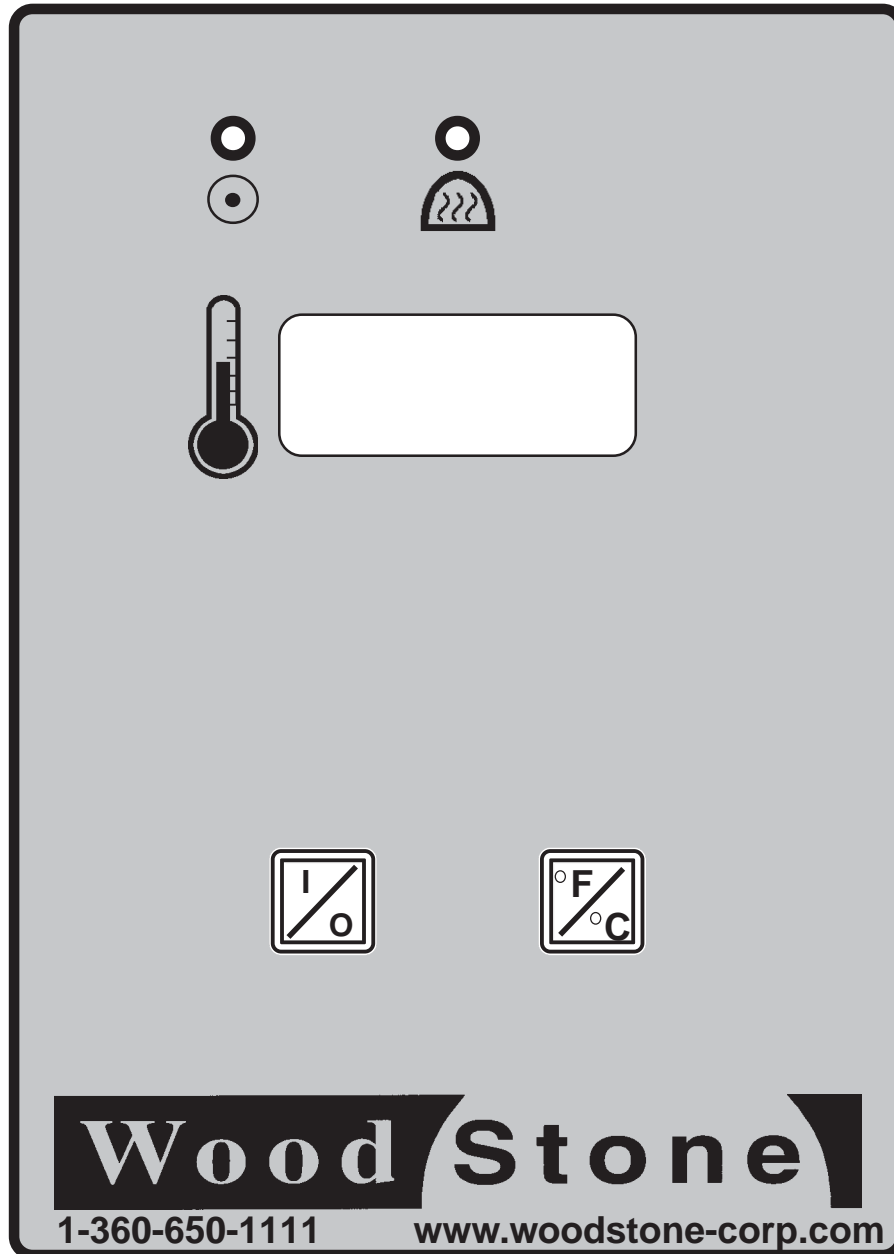

**Type 2 Controller**  
Used on models shipped before  
August 2005. See next page.



**Temperature Units-** press and hold to switch between Fahrenheit and Celcius.

**ON/OFF button-** press to turn oven on and off

**HearthTemperature-** The hearth temperature will be displayed here, any time the oven is turned on. Display will read 'LO' when the temperature is below 100 F.

### **Type 4 Controller**

Used on ovens shipped after August 2005.

## INITIAL OVEN STARTUP for RFG models

see page 12 for RFG-IR models

### **FIRST DAY**

1. Make sure main gas supply is on (valve parallel with gas line).
2. **Push the I/O button on the controller.** It may take a while for the gas to purge all the air from the gas lines.
3. Allow oven to operate for 1 hour with the radiant flame at its lowest setting.
4. After one hour, raise the flame to 25% (~16 cm flame), hold this setting for 4 hours.
5. After 4 hours @ 25% flame, raise to 50% flame and hold for at least another 4 hours.  
The oven can be left at this setting all night.

### **SECOND DAY**

Turn the radiant flame to 75% height.

*The floor temperature should reach 260 degrees C within about an hour. The oven is now ready for cooking; go to it!!*

## **General Daily Oven Operation**

### **END OF THE DAY**

1. Push the I/O button, all gas will go off, *even the pilot.*
2. Put oven door in place to retain heat.

### **BEGINNING OF THE DAY**

1. Remove oven door
2. Push the I/O button and turn the radiant flame to its highest setting. When the oven reaches the desired temperature, reduce flame height so that the desired temperature is maintained.

### **CLEANING THE OVEN**

1. As needed (twice per hour), use the floor brush to sweep stray food debris to the doorway, where it can be easily removed with a dough cutter or spatula.
2. As needed, swab the deck using a damp (not wet) rag wrapped around the floor brush.



***NEVER PLACE ANYTHING IN OR ABOVE THE RADIANT FLAME***

## DETAILED DAILY OVEN OPERATION

### for RFG models;

see page 13 for RFG-IR models



**IMPORTANT:** *If at any time you feel that the burner is not operating properly, TURN THE OVEN OFF and call for service. Before servicing, disconnect the electrical supply at the breaker and turn off the gas supply at the appliance's individual gas shutoff valve. In the event of a power failure, no attempt should be made to operate the oven.*

See pages 15 and 16 for an illustration of the RFG oven controller.

### 1. DAILY STARTUP

Press the I/O button to start the oven; the radiant flame will ignite.



**GREEN LIGHT:** indicates the system is energized.



**GREEN LIGHT:** indicates the pilot flame for the radiant burner is lit.

### 2. TURNING OFF THE OVEN

Push the I/O button on the controller to turn the oven off.

The burner will go out and the digital readout will go blank

### 3. ADJUSTING THE RADIANT (dome) FLAME

**To adjust the radiant flame:** The radiant flame is always on (when oven is operating) and can be adjusted to any flame intensity between its highest and lowest setting. Simply turn the knob located to the lower left of the doorway, beneath the mantle.



**STAINLESS STEEL DOORS:** The door(s) are used for nighttime heat retention. **NEVER operate the oven with door(s) in place.**

**DAILY MAINTENANCE:****Oven Interior**

Wood Stone recommends the use of a long-handled, brass bristled brush for sweeping aside excess food particles that will accumulate on the floor of the oven during use. **The oven floor can be cleaned with a damp rag. DO NOT USE ICE OR EXCESSIVE WATER ON THE FLOOR; THIS IS TO PREVENT THERMAL SHOCKING OF THE STONE.**

There is a stainless steel curb to prevent food from falling on and thereby obstructing the gas orifices of the radiant flame. ***If food gets into the radiant flame well and the flame is visibly obstructed, turn the oven off immediately, and call for service.***

**Oven Exterior**

All painted and stainless steel surfaces should be cleaned as necessary using an approved mild detergent, hot water and a soft cloth or sponge. Stubborn residues may be removed using a nonmetallic scouring pad. **When scouring stainless steel surfaces, scrub with the grain of the metal to prevent scratching.**

**IMPORTANT: DO NOT USE EXCESSIVE AMOUNTS OF LIQUID WHEN WIPING ON OR AROUND THE CONTROL BOX.**



**ALSO**

**DO NOT USE THE RADIANT BURNER WELL AS A DUMP FOR DEBRIS OR TRASH INCINERATION; MAKE EVERY ATTEMPT TO KEEP DEBRIS FROM DROPPING INTO THE WELL.**

**ESTABLISHING A THERMAL CLEANING SCHEDULE**

Wood Stone ovens are typically operated at temperatures which preclude the need for cleaning of the interior walls and ceiling (the dome) of the oven. If however, you routinely operate the oven at floor temperatures lower than 250 degrees C, you may notice a buildup on the interior walls and/or ceiling of the oven. If this is the case, use the following procedure to periodically clean the oven. The frequency of thermal cleaning will be determined by the amount of buildup experienced. The amount and rate of buildup will largely be determined by the type of food that is cooked in the oven, and by how long the oven is operated at temperatures low enough to allow buildup to occur.

**THERMAL CLEANING**

**Gas-fired Oven** If a Wood Stone gas-fired oven is operated at low temperatures, it is possible that grease from food could condense on the walls and ceiling of the oven. To remove the grease that has accumulated on the walls and ceiling of the oven, simply turn the radiant flame to its highest setting. Monitor the floor temperature displayed on the controller. When the floor reaches 350 degrees C, lower the flame slightly; maintain the oven floor temperature near 350 degrees for about an hour. Once the oven dome appears clean, allow the oven to return to its normal operating temperature and continue normal operation.

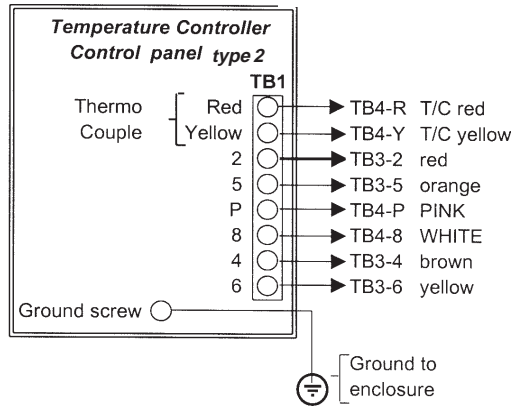

### RFG-IR-CE Ovens

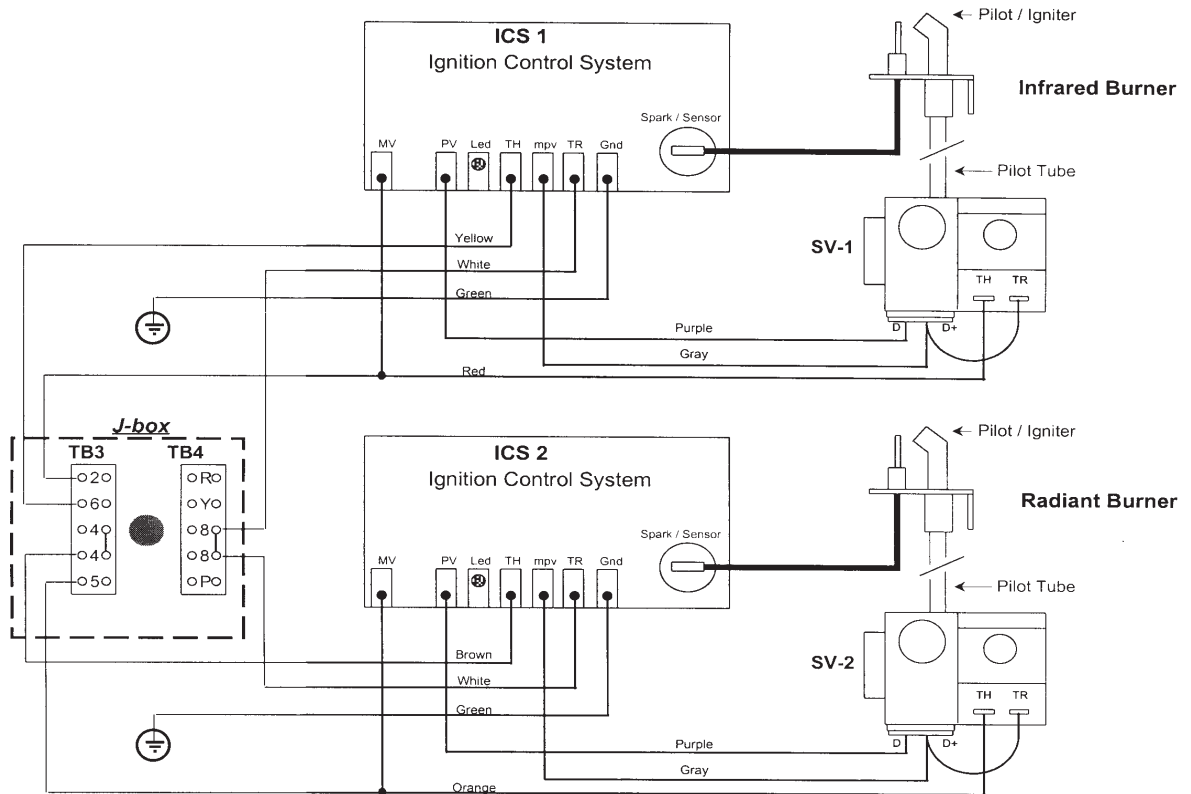
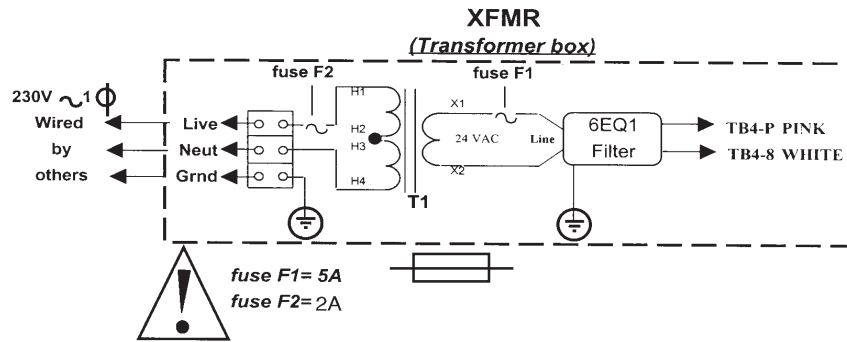

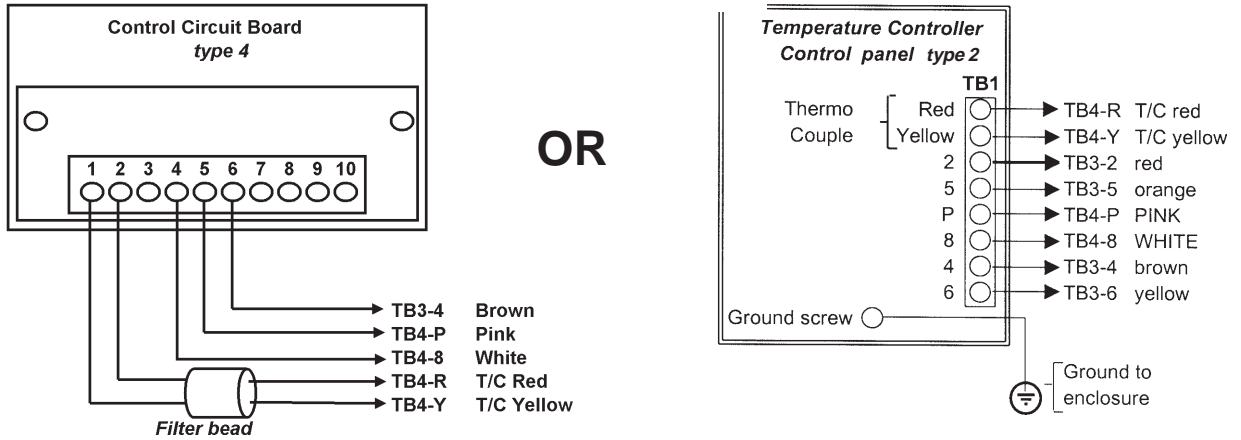

### RFG-CE Ovens

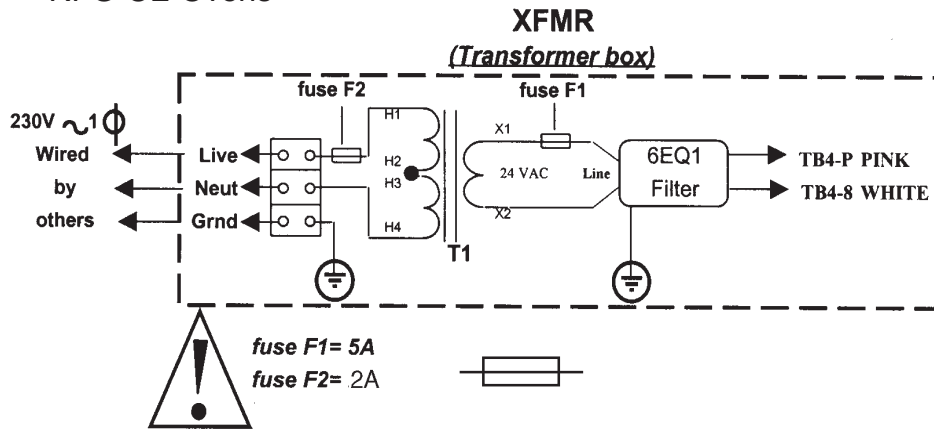

### Radiant Burner

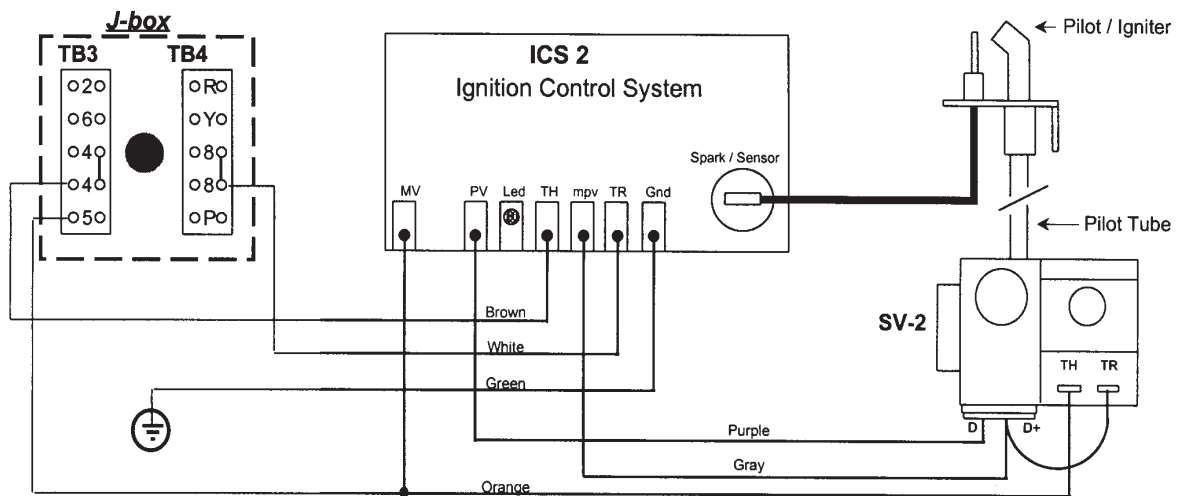

**Wood Stone warrants its equipment to the original purchaser against defects in material or manufacture for a period of one year from the original date of purchase, subject to the following exclusions and limitations.**

### **EXCLUSIONS**

The warranties provided by Wood Stone do not apply in the following instances:

1. In the event that the equipment is improperly installed. Proper installation is the responsibility of the installer; proper installation procedures are prescribed by the Wood Stone installation manual.
2. In the event the equipment is improperly maintained. Proper maintenance is the responsibility of the user; proper maintenance procedures are prescribed in the Wood Stone installation manual.
3. In the event that the failure or malfunction of the appliance or any part thereof is caused by abnormal use or is otherwise not attributable to defect in material or manufacture.
4. In the event that the appliance, by whatever cause, has been materially altered from the condition in which it left the factory.
5. In the event that the rating plate has been removed, altered or obliterated.
6. On parts that would be normally worn or replaced under normal conditions.
7. Normal cracking due to expansion and contraction stress relief in either the dome or floor blocks.
- 8. *In the event that pressed log products of any type have been burned in the equipment.***

If any oral statements have been made regarding this appliance, such statements do not constitute warranties and are not part of the contract of sale. This Limited Warranty constitutes the complete, final and exclusive statement with regard to warranties.

**THIS LIMITED WARRANTY IS EXCLUSIVE AND IN LIEU OF ALL OTHER WARRANTIES WHETHER WRITTEN, ORAL OR IMPLIED, INCLUDING, BUT NOT LIMITED TO, ANY WARRANTY OF MERCHANTABILITY OR FITNESS FOR PARTICULAR PURPOSE OR WARRANTY AGAINST LATENT DEFECTS.**

### **LIMITATIONS OF LIABILITY:**

In the event of warranty claim or otherwise, the sole obligation of Wood Stone shall be the repair and/or replacement, at the option of Wood Stone, of the appliance or component or part thereof. Such repair or replacement shall be at the expense of Wood Stone with the exception of travel over 100 miles or two hours, overtime, and holiday charges which shall be at the expense of the purchaser. Any repair or replacement under this warranty does not constitute an extension of the original warranty for any period of the appliance or for any component or part thereof. Parts to be replaced under this warranty will be repaired or replaced at the option of Wood Stone with new or functionally operative parts. The liability of Wood Stone on any claim of any kind, including claims based on warranty, expressed or implied, contract, negligence, strict liability or any other theories shall be solely and exclusively the repair or replacement of the product as stated herein, and such liability shall not include, and purchaser specifically renounces any rights to recover, special, incidental, consequential or other damages of any kind whatsoever, including, but not limited to, injuries to persons or damage to property, loss of profits or anticipated profits, or loss of use of the product.

### **TO SECURE WARRANTY SERVICE:**

If you claim a defect covered by this Limited Warranty, direct your claim to  
Wood Stone Corporation 1801 W. Bakerview Rd. Bellingham, WA 98226 USA Attn: National Service Manager

