





GSV 200-450 Grease Fan

USA

CAN



-  **Product Information** Chapter 1 + 2
-  **Mechanical Installation** Chapter 3
-  **Electrical Installation** Chapter 4
-  **Start Up and Configuration** Chapter 5
-  **Maintenance and Troubleshooting** Chapter 6

Job Name: _____

Installer: _____

Installation Date: _____



1. Product Information	
1.1 Function	3
1.2 Components.....	3
1.3 Shipping	4
1.4 Warranty.....	4
2. Specifications	
2.1 Dimensions & Capacities	4
3. Mechanical Installation	
3.1 Positioning.....	5
3.2 Installation on Steel Duct	5
3.3 Installation on Roof Curb.....	5
4. Electrical Installation	
4.1 Electrical Requirements	6
4.2 Wiring Diagram for GSV 250-315	6
4.3 Wiring Diagram for GSV 400-450	7
4.4 Start-up	8
5. Start-up & Configuration	
5.1 Start-up	8
6. Maintenance & Troubleshooting	
6.1 Maintenance Intervals	9
6.2 Cleaning	9
6.3 Spare Parts Ordering	9

Symbol Legend:

The following terms are used throughout this manual to bring attention to the presence of potential hazards or to important information concerning the product.



Danger: Indicates an imminent hazardous situation which, if not avoided, will result in death, serious injury or substantial property damage.



Caution: Indicates an imminent hazardous situation which, if not avoided, may result in personal injury or property damage.



TO REDUCE THE RISK OF FIRE, ELECTRICAL SHOCK OR INJURY TO PERSONS, OBSERVE THE FOLLOWING:

1. Use this unit in the manner intended by the manufacturer. If you have questions, contact the manufacturer at the address or telephone number listed on the front of the manual.
2. Before servicing or cleaning the unit, switch off at service panel and lock service panel to prevent power from being switched on accidentally.
3. Installation work and electrical wiring must be done by a qualified person(s) in accordance with applicable codes and standards.
4. Follow the appliance manufacturer’s guidelines and safety standards such as those published by the National Fire Protection Associations (NFPA), and the American Society for Heating, Refrigeration and Air

- Conditioning Engineers (ASHRAE), and the local code authorities.
5. This unit must be grounded.

How to use this manual

This installation manual does not contain any system design documentation. System design documentation is available from any authorized EXHAUSTO representative.

Accessories, like roof curbs and variable frequency drives, are not covered by this manual. Please refer to these component’s individual manuals.



1. Product Information

1.1 Function

Use EXHAUSTO Model GSV Grease Fan is designed to provide a large exhaust volume at a high discharge velocity. It is intended for use as a part of a restaurant kitchen exhaust system and grease applications according to NFPA 96. The use of the EXHAUSTO Grease Fan is not restricted to any type of chimney or grease duct. However, always follow the exhaust-hood manufacturer's instructions regarding the venting.

Construction

The fan housing is made of heavy cast aluminum and can be opened for easy cleaning. The impeller is of the backward inclined type. It is made of cast aluminum and has permanently attached balancing weights.

The motor is a direct-drive, variable speed, class H insulated, high temperature motor. It has permanently lubricated and sealed ball bearings and is maintenance free.

Listings

Installations must conform to the requirements of the authority having jurisdiction. Where required by the authority having jurisdiction, the installation must also conform to the NFPA 96. All electrical wiring must be in accordance with the requirements of authority having jurisdiction or, in absence of such requirements, with the National Electrical Code, NFPA 70.

EXHAUSTO Model GSV is tested and listed to UL Standard 705 for Power Ventilators and UL Standard 762 for Power Ventilators for Restaurant Exhaust Ventilators.

The model is also tested and listed to ULC-S645-93, Standard for Power Roof Ventilators for Commercial and Institutional Kitchen Exhaust Systems.

1.2 Components

The GSV Grease Fan consists of the following components:

- | | |
|-------------------------|--------------------|
| a. Top section | f. Locking hinge |
| b. Bottom section | g. Bird screen |
| c. Motor | h. Carrying handle |
| d. Centrifugal impeller | i. Wiring conduit |
| e. Inlet for impeller | |

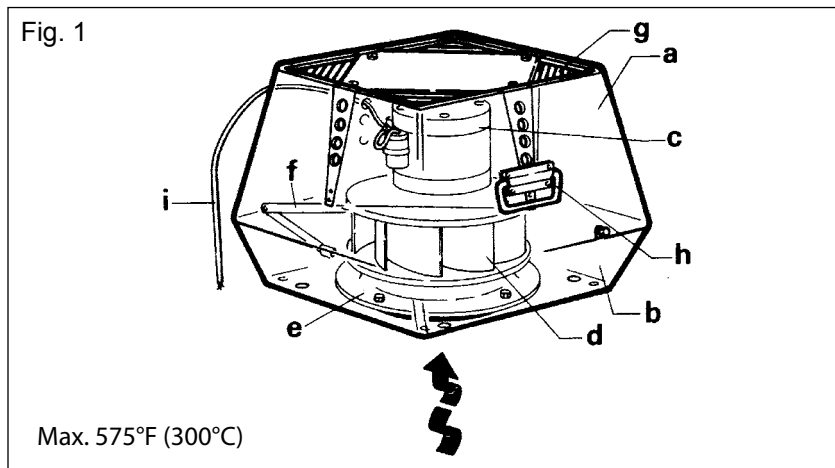

1.3 Shipping

Protection The fan is shipped in a corrugated cardboard box. If a transport securing device is attached (GSV 400 and GSV 450 only) to the bottom of the fan to hold the motor and impeller in place, do not remove it when unpacking the fan.



Do not remove the transport securing device until the fan is being installed on the duct or the roof curb. The motor shaft could be damaged.

NOTE:

All single phase fans are shipped with a capacitor and junction box connected via conduit. The capacitor is located **INSIDE** the junction box. Please do not discard.

1.4 Warranty

EXHAUSTO products are warranted for a period of two (2) years following the date of invoice. Replacement or repair will be at EXHAUSTO's discretion, provided factory inspection shows a defect in material or workmanship.

Complete warranty conditions are available from EXHAUSTO.



2. Specifications

2.1 Dimensions & Capacities

Model		GSV 200	GSV 250	GSV 315	GSV 400	GSV 450	
Discharge		Vertical					
Fan Type		Centrifugal Impeller					
Max. Discharge Velocity	FPM	1,729	2,222	2,771	2,752	4,134	
Actual Discharge Velocity	FPM	2.9xCFM	1.9xCFM	1.2xCFM	1.03xCFM	1.03xCFM	
Voltage	VAC	1 x 120			3x208-240 / 3x380-420		
RPM		1600			1680	1720	
Amps	A	1.4	2.9	5.8	3.5	6.5	
Power Ratings	kW	0.10	0.16	0.35	0.75	1.5	
		0.15	0.2	0.5	1.0	2.0	
Weight	lbs	47	60	92	127	155	
	kg	18	26	42	58	70	
Dimensions	A	in	11.03	13.20	16.94	16.94	23.23
		mm	280	335	430	430	590
	B x B	in	15.37	19.11	25.61	25.61	25.61
		mm	390	485	650	650	650
	C x C	in	12.22	15.17	20.69	20.69	20.69
		mm	310	385	525	525	525
	D Ø	in	7.88	9.85	15.76	15.76	15.76
		mm	200	250	400	400	400
	E	in	3.15	3.94	5.12	5.12	8.54
		mm	80	100	130	130	217
Soft Start Required		No	No	No	Yes ¹⁾	Yes ¹⁾	
Variable Speed Motor		Yes	Yes	Yes	Yes	Yes	
FA Sones			3.9	6.3	7.8	8.3	

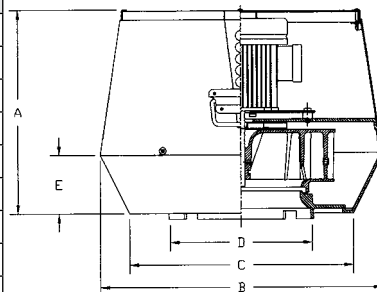

1) Not required if using a VFD



3. Mechanical Installation

3.1 Positioning

In accordance with NFPA 96, roof mounted fans shall have their discharge outlet at least 40 inches above the roof surface.

3.2 Installation on Steel Duct

- Insert the adapter (FR) into the grease duct, where the long collar engagement ensures safe anchoring (See Fig. 2). If necessary, the adapter can be secured by means of long self-tapping stainless steel screws into the side of the collar through the chimney wall. Do not obstruct the grease flow.
- Place the neoprene gasket (not shown) on top of the adapter.
- Remove the transport securing device (if present) holding the motor shaft and impeller in place.
- Place the fan on the neoprene gasket centered over the cutout.
- Open the fan and secure the fan onto the adapter, through the pre-drilled holes in the bottom, with lag bolts or self-tapping sheet metal screws, one at each corner.
- Check the gasket to insure that it forms a complete seal.



Caution: Never place hands or fingers on top of fan base when closing

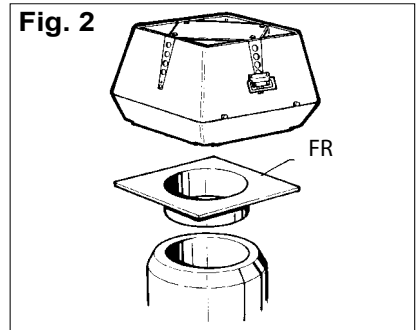

3.3 Installation on Roof Curb

- If the fan is supplied with a curb cap, secure the cap to the roof curb with self-tapping sheet metal screws (see Fig. 3).
- Place the neoprene gasket on the top of the curb cap with the hole centered over the curb cap opening (not shown).
- Remove the transport securing device (if present) holding the motor shaft and impeller in place.
- Place the fan on the neoprene gasket centered over the cutout.
- Open the fan and secure the fan onto the roof curb, through the pre-drilled holes in the bottom, with lag bolts or self-tapping sheet metal screws, one at each corner.
- Check the gasket to insure that it forms a complete seal.



Caution: Never place hands or fingers on top of fan base when closing

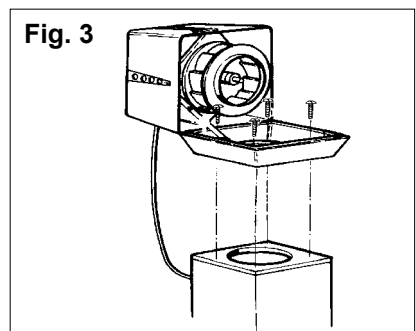

⚡ 4. Electrical Installation

4.1 Electrical Requirements

Power requirements depend on the fan size. They can be found on page 4.



Danger: Turn off electrical power before servicing. Contact with live electric components can cause shock or death.



Notice: If any of the original wire supplied with the system must be replaced, use similar wire of the same temperature rating. Otherwise, insulation may melt or degrade, exposing bare wire.

4.2 Wiring Diagram for GSV 250-315

The connection diagram below shows how the fan is connected to the fan speed control and the power source (see Fig. 6).

Use a 2-conductor wire of min. 14 AWG with ground. Wiring must be run outside the duct, but can be run between the duct and the roof curb.

Fig. 5 shows the wiring of the capacitor in the junction box.

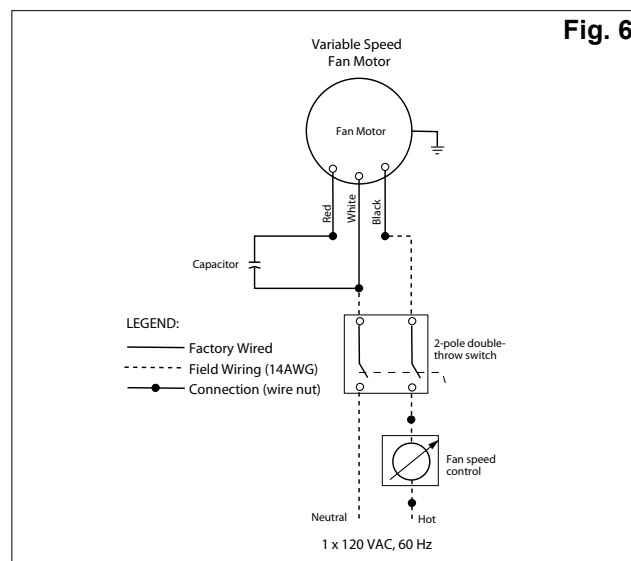
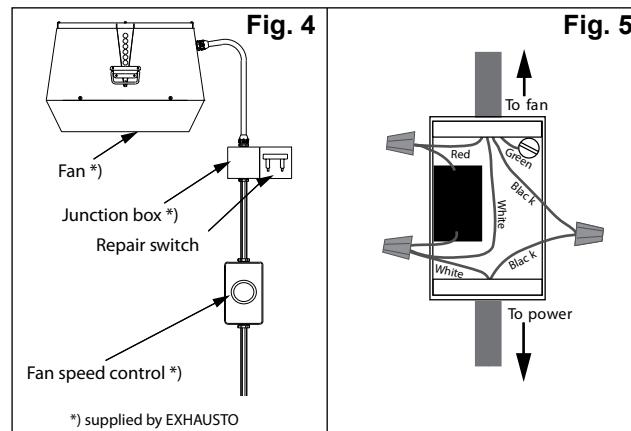

4.3 Wiring Diagram for GSV 400-450

The connection diagram below shows how the fan is connected to the power source (see Fig. 7).

Use a 3-conductor wire of min. 14 AWG with ground. Wiring must be run outside the duct, but can run between the duct and the roof curb.

If variable speed is required, a variable frequency drive (VFD) can be used. This will eliminate the need for a magnetic starter as shown. For installation and wiring, please refer to the instructions shipped with the VFD.

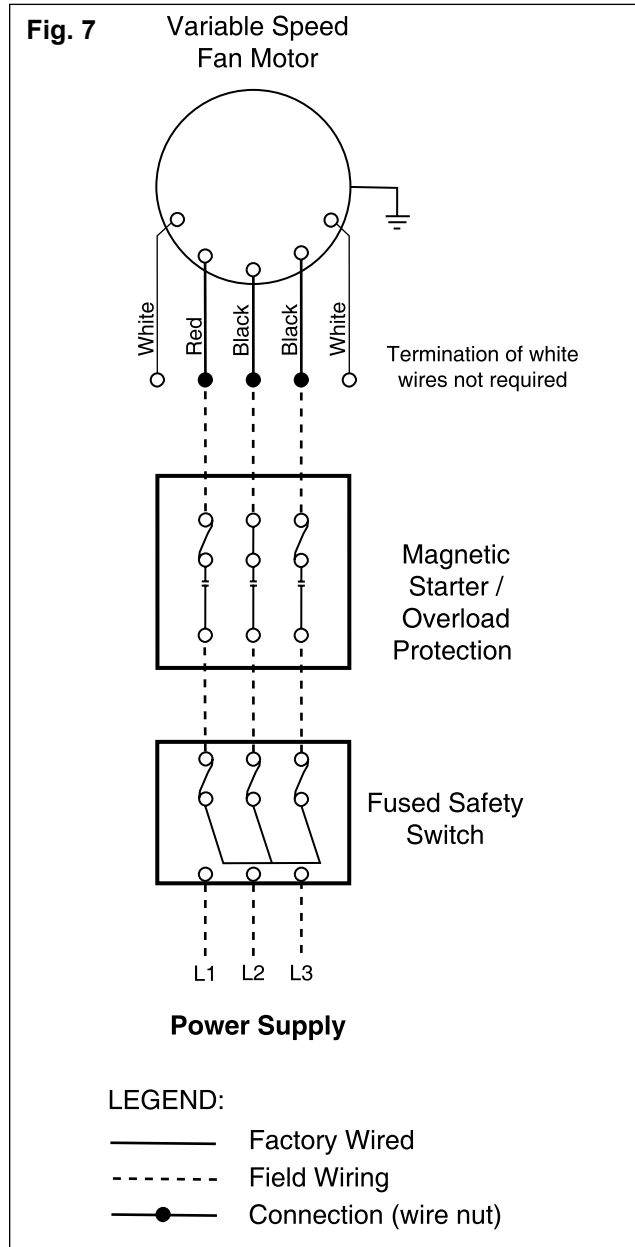

4.4 Dual Voltage Motor Wiring

GSV 400-450 can operate at either 3x208-230 VAC or 3x440-480 VAC (default).

The motor wiring terminals in Fig. 8 show default jumper positions for 3x440-480 VAC operation.

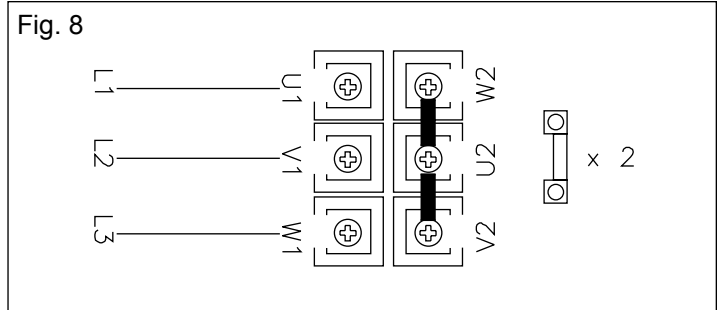

If the application requires 3x208-230 VAC operation, the jumper positions must be changed according to Fig. 9.

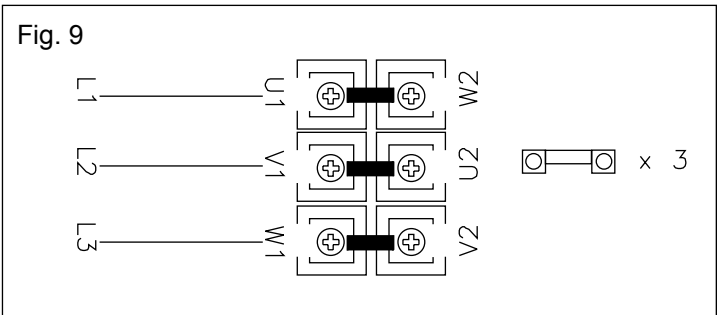

After wiring, make sure the motor is rotating in the proper direction. This is marked on the motor end cover. If the rotation is incorrect, swap the two wires going to the motor terminals, U1 and W1.



5. Start-up and Configuration

5.1 System Testing

- Check the voltage with the motor nameplate rating.
- Check that the transport securing device holding the motor shaft and impeller in place has been removed.
- Determine if the impeller is free and has not been subject to misalignment in shipping or installation.
- Apply power and check that the impeller is rotating in the direction of the arrow on the side of the top motor cover. All EXHAUSTO fans run in a counterclockwise direction when viewed from the top. Double check if three phase motor is tested on temporary wiring. Switching any two leads will reverse the rotation.

5.2 Adjusting the Fan Speed

Start all heating appliances connected to the chimney with the fan installed. Set the fan speed control to the speed where no spillage is experienced anywhere in the system.



6. Maintenance and Troubleshooting

6.1 Maintenance Intervals

The EXHAUSTO Grease Fan is designed for prolonged use. For dirty or grease-laden exhaust, inspect the impeller after (3) months and set up a periodic inspection based on these findings. Clean as required.

The fan motors are equipped with permanently lubricated sealed ball bearings. They require no lubrication.

6.2 Cleaning



Warning: Do not open the motor housing unless power to the grease fan has been disconnected

- Loosen the two Phillips screws in the front of the unit.
- Tilt the top of the fan by lifting on the handle. Make sure the locking arm holds the top of the fan before letting go.
- If necessary, use grease remover and a high-pressure cleaner to clean the impeller and the inside fan base.
- A scraper may also be used.



Caution: Never place hands or fingers on top of fan base when closing.

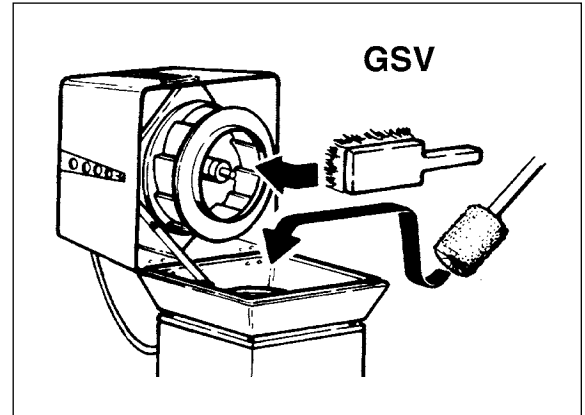

6.3 Troubleshooting

Problem	Possible Cause	What to do
The fan is not operating.	No power to the fan.	Check the power supply wires in the junction box by the fan. Check the circuit breaker. Check that the fan is actually turned ON.
The fan is not running at full speed and/or is humming.	The capacitor is improperly connected or not connected at all (single-phase fans only).	Check the connections inside the junction box. The capacitor must be installed according to wiring diagram.
The fan is rotating backwards (RSV 400/450 only).	Phase sequence in the power to the fan is reversed.	Swap two phases in the junction box.
The fan is vibrating vigorously.	The motor shaft is damaged.	Turn the power off immediately. Open the fan and check if the shaft is straight. If not, contact EXHAUSTO.
The fan is noisy.	A transportation device has not been removed. Foreign matter is stuck in the fan. A ball bearing is damaged.	Remove the transportation device. Turn off the power and remove the foreign article. Turn off the power. Wait for the motor to stop revolving. Spin the wheel and listen for any grinding noise from the motor. If necessary, replace bearing.
The fan stops in the middle of a firing cycle.	The motor is overheating.	Check the flue gas temperature below the fan. The temperature should not exceed 400°F during continuous operation. Call EXHAUSTO.

6.3 Spare Parts Ordering

When ordering spare parts, please have the model number and part position number available

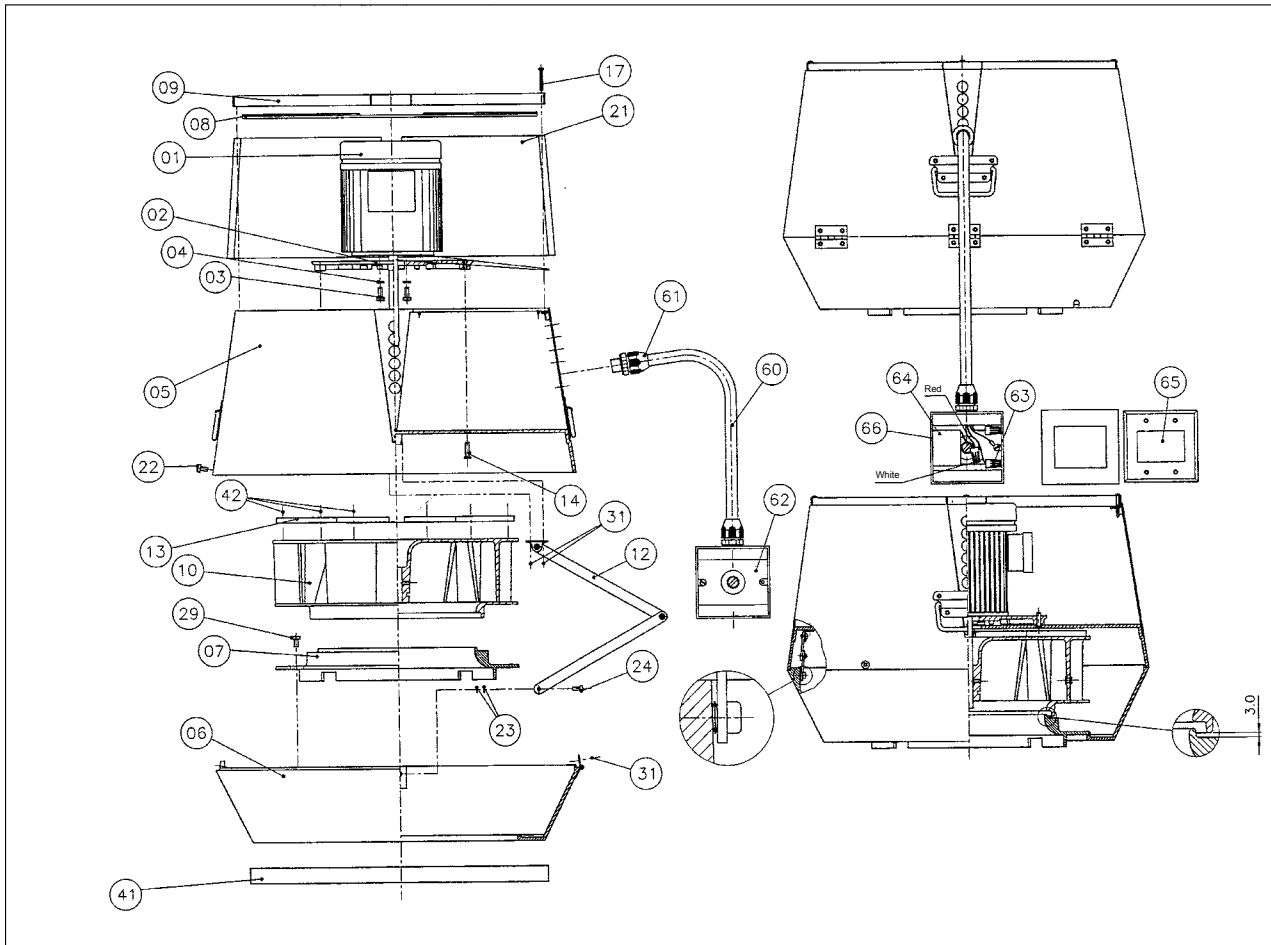

01	Motor	21	Motor housing insulation
02	Motor mounting plate	22	Screw - SS (2)
03	Screw - SS (2)	23	Washer - SS (2)
04	Washer - SS (2)	24	Screw - SS
05	Housing (top)	29	Screw - SS (4)
06	Housing (base)	31	Rivet (2)
07	Impeller seat	41	Neoprene Gasket
08	Bird screen	42	Rivet (12)
09	Top plate	60	3/8" Conduit
10	Aluminum Impeller	61	3/8" Connector
12	Locking hinge	62	Junction box with blank cover
13	Cooling vane	63	Wire nuts (4)
14	Screw - SS (4)	64	Capacitor (1x120V fans only)
17	Screw - SS (4)	65	Wiring diagram (mounted on inside cover)

DK: EU-Overensstemmelseserklæring GB: Declaration of Conformity D: EU-Konformitätserklärung F: Déclaration de conformité de l'Union Européenne	N: EU-Overensstemmelseserklæring NL: EU-Konformiteits verklaring S: EU-Överensstämmedeklaration SF: EU-Vaatimustenmukaisuusvakuutus IS: ESS-Samræmisstaðfesting
EXHAUSTO A/S Odensevej 76 DK-5550 Langeskov DANMARK	
erklærer på eget ansvar, at følgende produkter: declare on own responsibility that the following products: Verantwortet, daß folgende Produkte: déclare sous sa propre responsabilité que le produit suivant:	erklærer på eget ansvar, at følgende produkter: veklaard dat onderstaande produkten: deklarerar på eget ansvar, att följande produkter: vastaa siltä, että seuraava tuote: Staðfesti á eigin ábyrgð, að eftirfarandi vörur:
GSV009, GSV012, GSV014, GSV016, GSV200, GSV250, GSV315, GSV400, GSV450	
som er omfattet af denne erklæring, er i overensstem- melse med følgende standarder: covered by this declaration, are in conformity with the following standards: mit den folgenden Standardbezeichnungen: auquel s'applique cette déclaration est en conformité des normes mentionnées ci-dessous:	som er omfattet av denne erklæring, er i overensstem- melse med følgende standarder: met de onderstaande standard koderingen: som omfattas av denna deklaration, överensstämmer med følgende standarder: joka koostuu tästä selvityksestä, on seuraavien standar- dien mukainen: sem eru meðalín í staðfestingu Pessari, eru í fullu sam- ræmi við eftirtalda staðla:
EN 60 335-1, EN 60 335-2-80, DS/EN ISO 12100-1, DS/EN ISO 12100-2	
i.h.t bestemmelser i direktiv: according to conformity in directive: gemäß folgenden EU-Richtlinien überstimmen: suivant les dispositions prévues aux directives:	i.h.t bestemmelser i direktiv: voldoen aan de heironder gestelde eisen: enligt bestämmelserna i följande direktiv: seuraavien direktiivin määräysten mukaan: med tilvisun til ákvarðana eftirlits:
Maskindirektivet: Machinery Directive: für Maschinen: La directive des machines:	Maskindirektivet: voor machines: Maskindirektivet Konedirektiivi: Velaeftirlitið:
98/37	
Lavspændingsdirektiv: Low voltage Directive: für Niederspannung: La directive de la basse tension:	Lavspændingsdirektiv: laagspanning: Lågspänningsdirektiv: Matalajännitedirektiivi: Smáspennueftirlitið:
73/23	
EMC-direktivet: EMC Directive: für EMC: La directive de la compatibilité électromagnétique:	EMC-direktivet: voor EMC: EMC-direktiv: EMC-direktiivi: EMC-efirlitið:
89/336, 92/31	
Langeskov, 9.13.01 Adm. direktør Managing Director Geschäftsführer, Inhaber Président-directeur général Peter Hermansen 