

# Wood Stone

## MT. CHUCKANUT 4'

Stone Hearth Oven



Oven shown with optional stainless steel mantle.

**Job Name**

**Model** WS-MS-4-RFG-CE

**Item#**

**Fuel Type** Radiant Flame, Gas-Fired

### Hearth Capacity

200 mm pizzas	8-10
250 mm pizzas	5-6
300 mm pizzas	4
400 mm pizzas	1-2

Assuming 5-minute cook times, the approximate maximum hourly production capacity can be calculated by multiplying the above numbers by 12.

**Note:** Highlighted capacities are considered an operational challenge.

### OPTIONAL ACCESSORIES

- Doorway and Service Panel Extensions
- Stainless Steel or Black Granite Mantles
- Stainless Steel Oven Tools
- Custom Finishes
- Exhaust Fan
- Exhaust Hood
- Custom Wood Burning Accessories
- Wood Burning Option

The Mt. Chuckanut Radiant Flame, Gas-Fired oven features a standard door opening 500 mm wide x 250 mm high. The inside diameter of the oven floor is 940 mm, resulting in a .9-square-meter cooking surface. The oven is suitable for installation with only 25 mm side clearance to combustible building materials.

The dense, high-temperature ceramic formulation of which the hearth and dome are cast creates a "deep heat sink" within the chamber of the oven. The oven is heated by an easily adjustable wall of radiant flame (19.9-kW max.) located at the rear of the cooking chamber.

The 295-Kg, monolithic, 100 mm thick, cast-ceramic floor sits on 100 mm of rigid insulation. The 320-Kg, monolithic dome is cast to a thickness of at least 100 mm. The hearth and dome are connected and supported by a carefully tensioned steel exoskeleton, which ensures structural integrity and long life. The body of the oven rests on a 12-gauge steel pan bolted to a heavy-duty, 75 mm angle iron stand. The oven is wrapped with at least 50 mm of spun ceramic fiber insulation and enclosed (top and sides) with 16-gauge galvanized steel. The oven arrives completely assembled and ready to set in place.

The Mt. Chuckanut can be manufactured to burn either propane or natural gas; this must be specified at the time of order.

The Mt. Chuckanut vents through an 203 mm O.D. flue collar located above the doorway. The oven must be vented as a Type A or Type B<sub>11</sub> appliance, and in accordance with all applicable codes.

Wood Stone's Radiant Flame Gas-Fired ovens can be manufactured to be fully and easily convertible to Dual Burner Gas-Fired ovens (this must be specified at time of order).

### NATURAL GAS (METHANE)

**I2H(20)** for use in: AT, DK, ES, FI, IE, IT, PT, GB, SE, CH, GR, CR

**I2E(20)** for use in DE

**I2L(25)** for use in NL

### PROPANE and PROPANE BLENDS

**I3+ (28-30/37)** for use in: IE, ES, FR, IT, PT, BE, CH, CR, and GB

**I3P(30/37/50)** for use in: DE, IE, ES, FR, PT, NL, CH and GB

**I3B/P (28-30/37)** for use in: DE, SE, AT, DK, FI, NL, CH, NO, FR

**I3P (30/37/50)** for use in: BE, DE, ES, FR, IR, IE, NL, PT, GB, IS, GR, CY, EE, HU, LV, MT, SI, CH

**I3B/P(50)** for use in: DE, SE, AT, DK, FI, NL, CH, FR

**I2ELL** for use in DE



**Wood Stone**

An ongoing program of product improvement may require us to change specifications without notice.  
Revised July 2010

### WOOD STONE CORPORATION

1801 W. Bakerview Rd.  
Bellingham, WA 98226 USA

Toll Free (800) 988-8103

Tel (360) 650-1111

Fax (360) 650-1166

[info@woodstone-corp.com](mailto:info@woodstone-corp.com) or visit [www.woodstone-corp.com](http://www.woodstone-corp.com)



# MT. CHUCKANUT 4'

Stone Hearth Oven

Model

WS-MS-4-RFG-CE

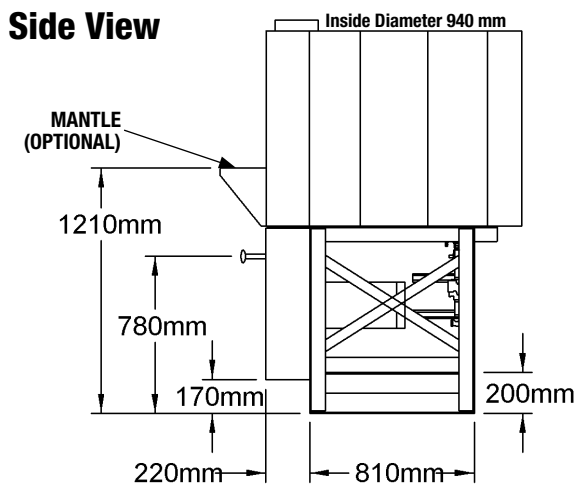
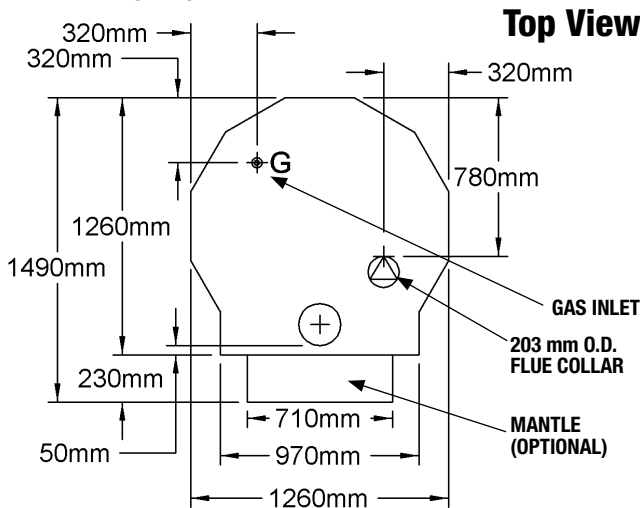
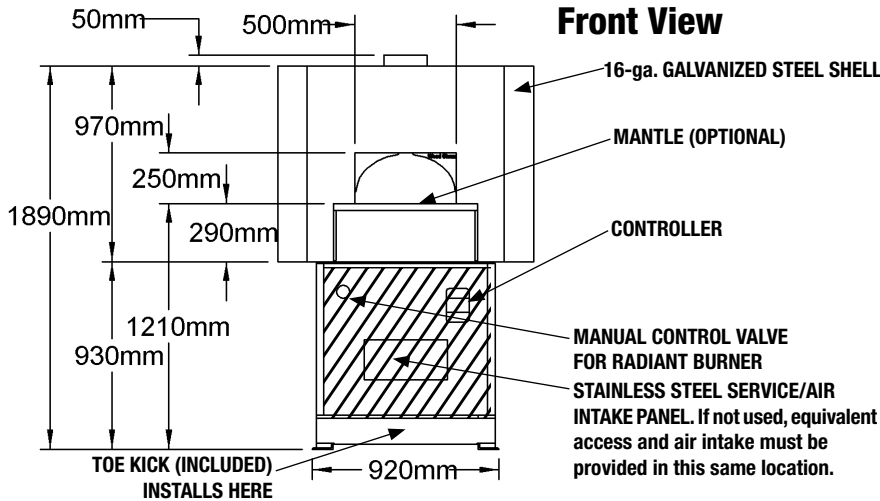

### UTILITIES REQUIRED:

1. 230-VAC/ 0.5 AMP Electrical Supply
2. 19.9-kW Natural Gas Supply (G20 at 20mbar)  
OR  
17.6-kW Propane (LP) Supply (G31 at 37mbar)

### FACADE INFORMATION

1. All facades or enclosures are by others; see installation information for details.
2. Any facade or enclosure below the mantle must allow the following:

- a) Unobstructed access 410 mm to each side of centerline for removal of service / intake panel.
- b) Easy access to all controls.
- c) Sufficient combustion air for gas burner; see installation information for details.

### VENTING INFORMATION

The Mt. Chuckanut vents through an 203 mm O.D. flue collar located above the doorway. The oven must be vented as a Type A or Type B<sub>11</sub> appliance, and in accordance with all applicable codes.

**Unit Shipping Weight:**  
**1,090 Kg**



An ongoing program of product improvement may require us to change specifications without notice.  
Revised July 2010

### WOOD STONE CORPORATION

1801 W. Bakerview Rd.  
Bellingham, WA 98226 USA

Toll Free (800) 988-8103

Tel (360) 650-1111

Fax (360) 650-1166

info@woodstone-corp.com or visit [www.woodstone-corp.com](http://www.woodstone-corp.com)