

### ROLLOVER CAGE

---

#### GOT A CHALLENGING INSTALLATION?

No problem. We have options. Wood Stone Mountain Series Ovens can be shipped with an optional **Rollover Cage** to facilitate removal from the stand in order to fit it through a smaller doorway.

---

#### STEP 1. Order the oven with Rollover Cage

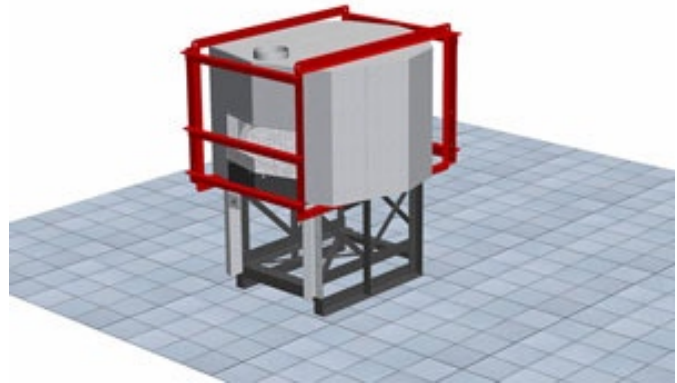

---

**STEP 2.** Remove gas and electrical components. (All ovens ship fully assembled. Contact Wood Stone for a recommended service agency in your area that can remove and reinstall the gas and electrical components. This must be performed by a qualified technician to maintain the warranty).

---

**STEP 3.** Rig the oven off of the stand (we recommend that you hire a professional rigger).

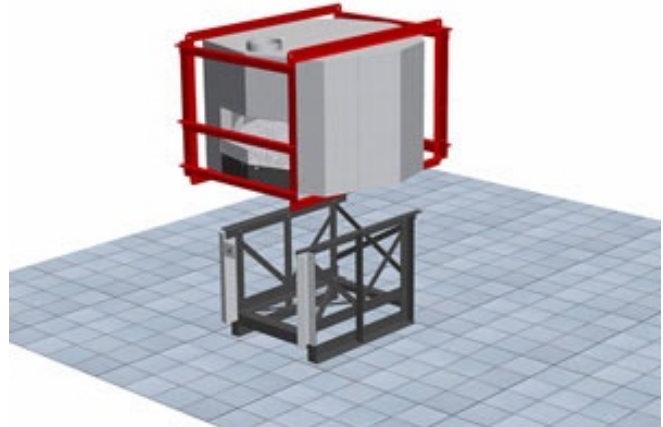

**STEP 4.** Oven is ready to turn.

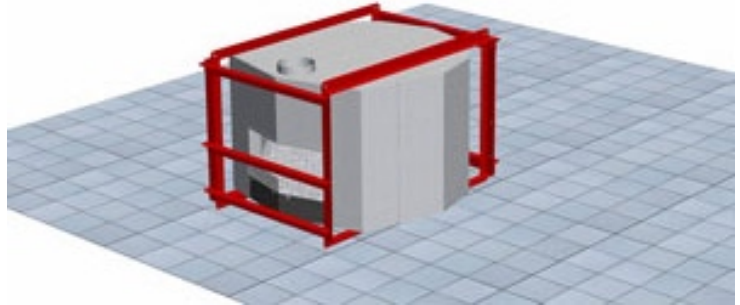

**STEP 5.** Tip oven / Rollover Cage on to its back.

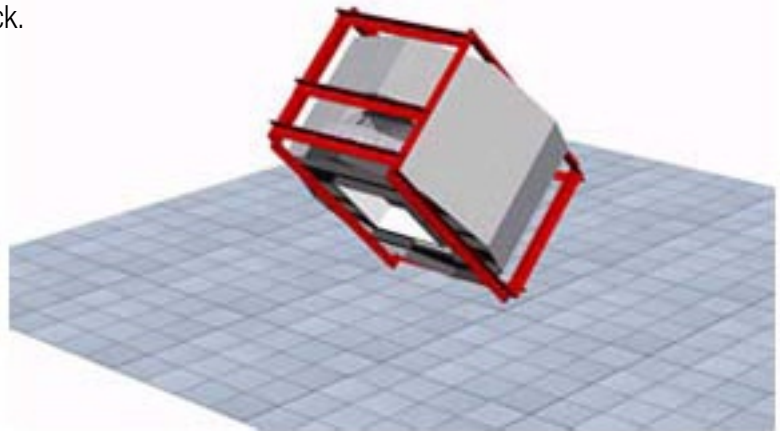

**STEP 6.**

Take oven through the door opening using a pallet jack or sturdy dollies.

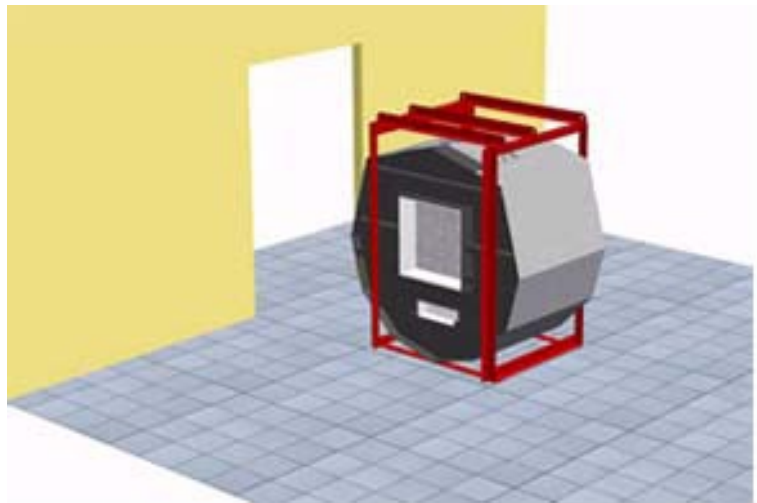

### DIMENSION INFORMATION

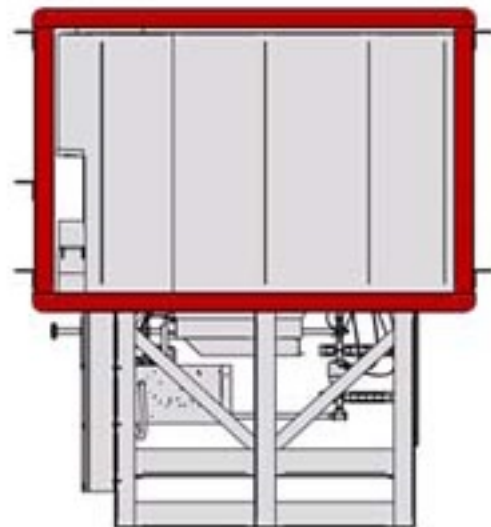
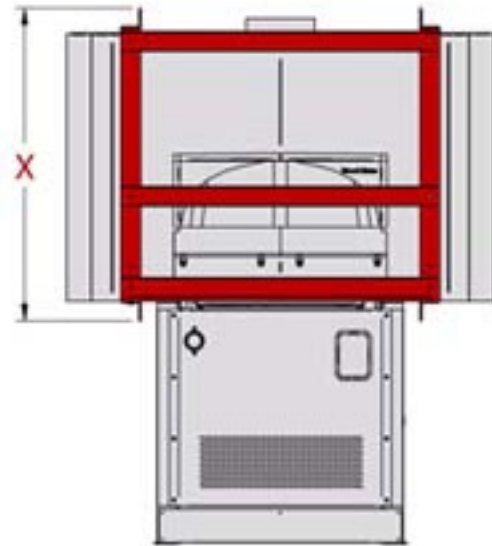
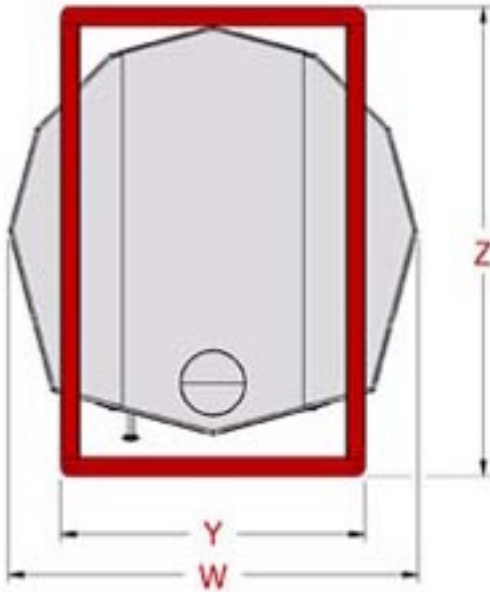

OVEN	W	X	Y	Z
<b>MT. CHUCKANUT (4')</b>	50"	45"	42"	65"
<b>MT. ADAMS (5')</b>	64"	47"	48"	75"
<b>MT. BAKER (6')</b>	76"	47"	54"	88"
<b>MT. RAINIER (7')</b>	88"	51"	71"	101"

**NOTE:** **X** and **Z** are the critical dimensions. **X** represents the width of the opening you will need. **Z** represents the height. **W** equals the width of the oven.

**NOTE:** The **Z** dimension (the dimension which determines the door height that the oven in the rollover cage can fit through) includes enough height to accommodate a facade extension. If it is a tight fit and the **Z** dimension noted here is too tall, we can provide a custom rollover cage. Please contact the factory for more information if you think a shorter version might be needed.