

### FINISHING YOUR OVEN: A FACADE TUTORIAL

#### VARIATION: MT. CHUCKANUT 4' OVEN

These illustrations refer to a facade on a Mt. Chuckanut 4' gas/gas (RFG-IR) oven. Keep in mind as you read through this tutorial that we make Facade Extensions that can make much of this installation process easier. Be sure to view our Facade Extension page for details.

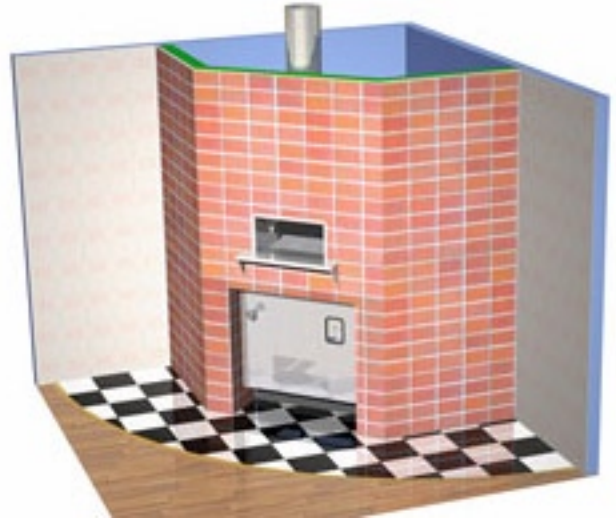

#### STEP 1. THE BASE OVEN

Figure 1.1 Represents a standard **WS-MS-4-RFG-IR** oven. Specs for additional sizes are available in our online Product Catalog and CAD Symbols in our CAD Library.

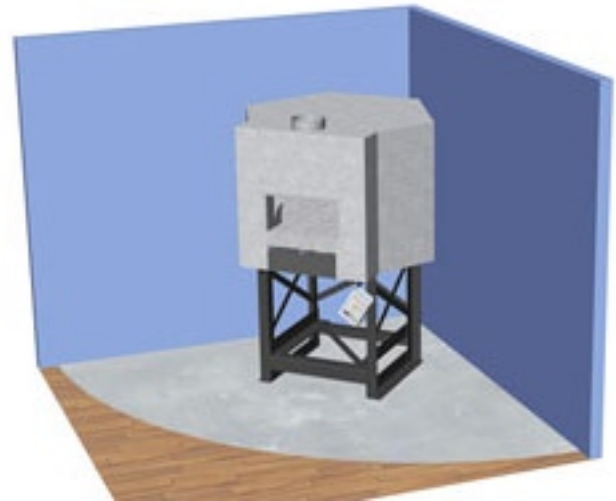

Figure 1.1

**Figure 1.2** Mount the Service Panel, Toe Kick and optional Mantle according to the instructions in the installation manual. Please note the location of the Toe Kick, it ships unattached and is installed at a small offset from the Service Panel to maintain room for combustion air. See the **Airflow Detail** on **page 7**.

**Note:** The Service Panel must remain removable for access to the under part of the oven.

Connect the **Flue** to the oven's flue collar. Please note this flue must be a "grease duct".

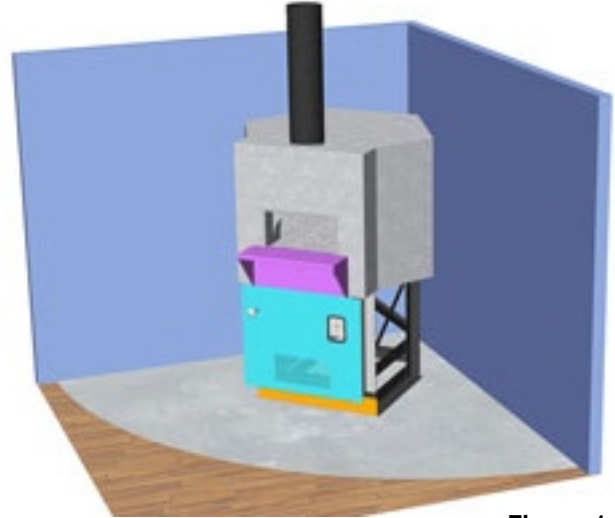

Figure 1.2

### STEP 2. STUD WALL

The stud wall is built. Metal studs are recommended. Consideration must be given to the wall framing position to insure the minimum one-inch offset from the back of the wall surface (sheetrock) to the oven sheet metal.

In addition, the studs on either side of the doorway must be far enough apart so that when sheet rock and tile are installed, the Service Panel can still be removed for oven service.

Note that the control box is mounted in the Service Panel where it is convenient for the chef to operate (The control box can be remounted in a different position, but you will need to specify at the time of order so that we can plug the service panel hole and ship the controller with a longer lead).

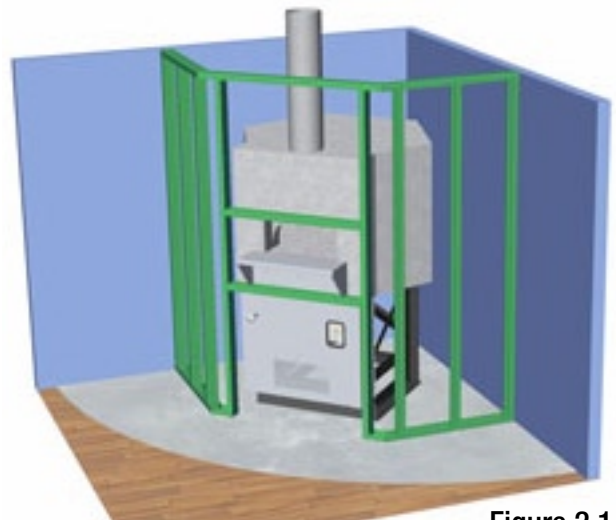

Figure 2.1

### STEP 3. CUSTOM FABRICATION

Shown in Figure 3.1 in red is a customer-fabricated throat extension for the unique requirements of the installation architecture. (This piece is required if **Doorway Facade Extensions** are not purchased from Wood Stone).

On top is the doorway surround, which should be metal and is usually stainless steel for sanitation reasons. It should fit snugly and be welded to the inside lip of the oven doorway to lock it in position.

**Note:** The custom fabricated doorway span should not block or obstruct ventilation through the flue.

The service panel surround below can be sheet metal as well, but need not be stainless if it is to be facaded. Both however, must be of non-combustible material (since they touch the oven).

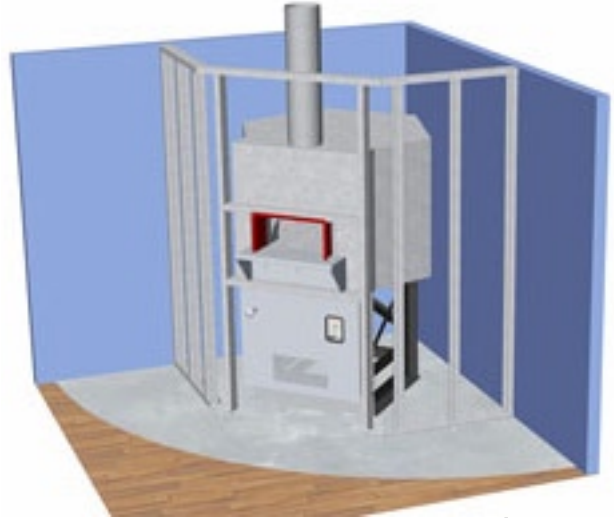

Figure 3.1

---

### ADDITIONAL FACADE EXTENSION OPTIONS



Figure 3.2



Figure 3.3



Figure 3.4

### STEP 4. NON-COMBUSTIBLES

Seen here in yellow is the non-combustible wallboard. This is required directly over the oven doorway and 6" on either side of the doorway.

Non-combustible material is also required anywhere the facade touches the oven or the mantle. In this illustration, the non-combustible wallboard is used as flashing from the studs to either side of the service panel and contacts the edge of the mantle.

Usually a cement board is used for this application. Brand names of appropriate underlayment include **Wonderboard** and **DUROCK**. (Drywall is considered a combustible and should not be used).

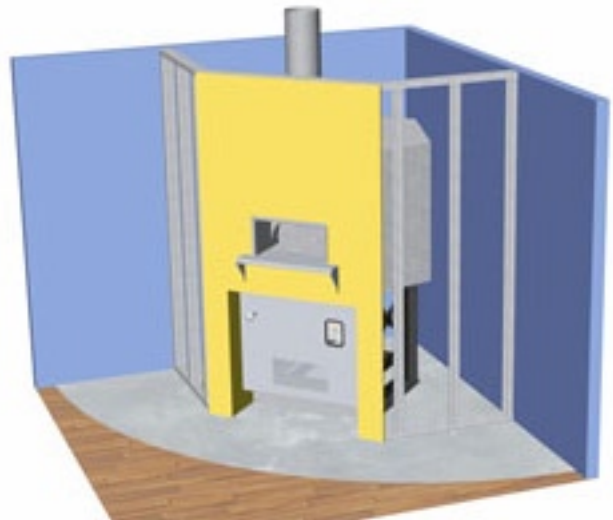

Figure 4.1

### STEP 5. ADDING DRYWALL

Shown in the lighter yellow is the drywall applied to the stud wall. This portion does not need to be non-combustible.

For the sake of simplicity of construction, many installers choose to make the entire wall out of the non-combustible cement board mentioned above as to avoid cutting many oddly shaped segments.

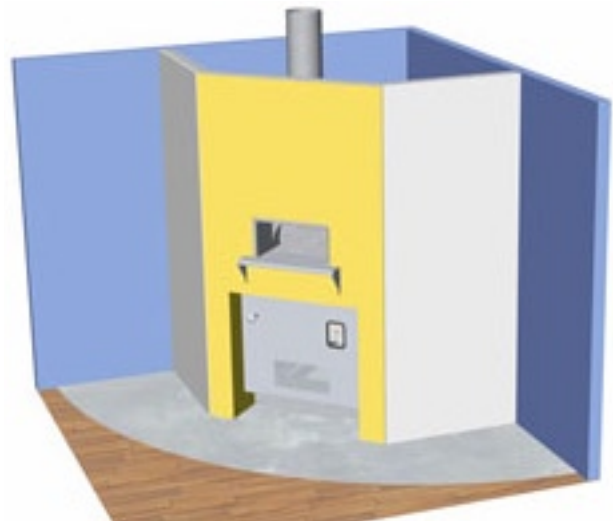

Figure 5.1

### STEP 6. FINISHING

Drywall can be finished with any decorative material that can be easily affixed to the wall surface such as tile, stucco, sheet metal, brick, etc.

**Note:** It is necessary for the proper operation of our ovens that the Radiant Flame Control Knob be fully accessible after all finishing is completed. This knob controls temperature in our gas ovens, if you cannot adjust the knob, you cannot adjust the temperature.

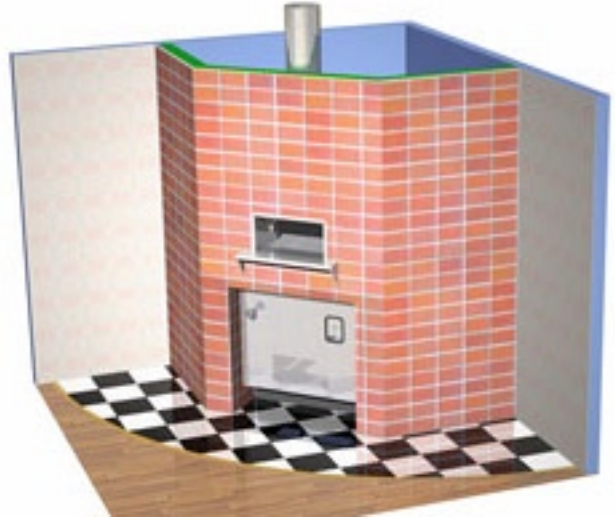

Figure 6.1

**GO TO NEXT PAGE FOR MT. SERIES FACADE SPECIAL DETAILS**

### STANDARD WALL FACADE SPECIAL DETAILS

#### OFFSET DETAIL

**Note:** The studs maintain 1" clearance from the oven. If these are metal studs they may touch the oven, however, **THEN** the 1" clearance to combustible construction must be maintained from the surface of the finished wall (in other words, no stacking napkins or wood next to the oven facade). If there is an airspace between the metal stud, and a minimum of 1" to the wallboard, you will be able to stack combustibles next to the facade.

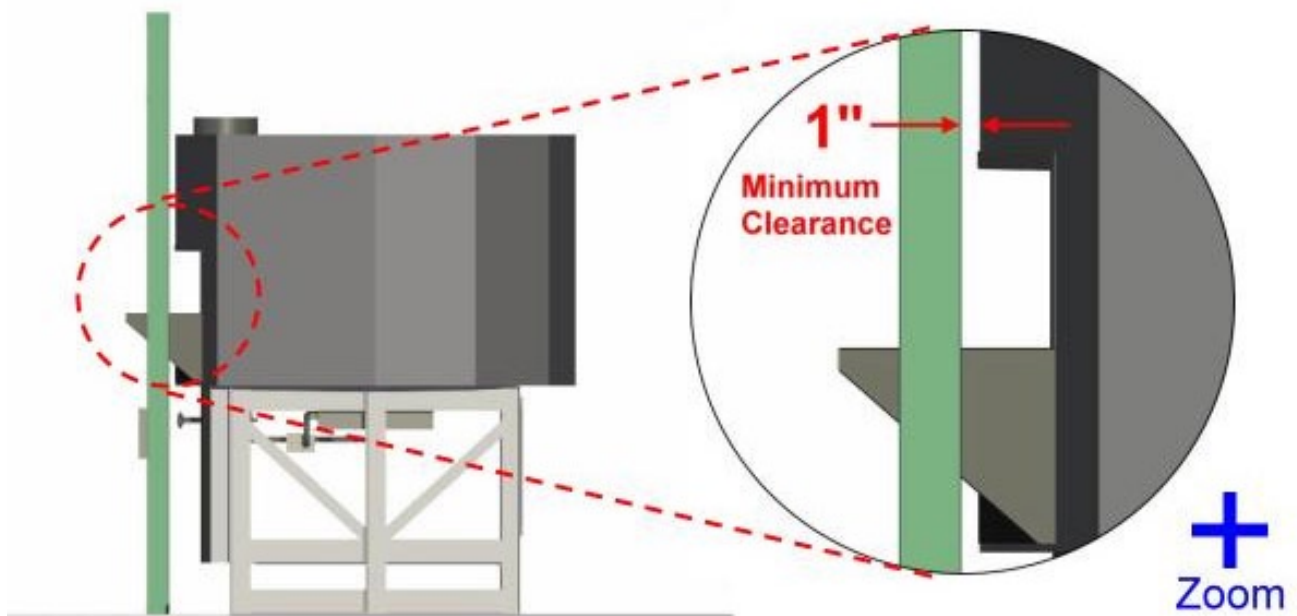

### STANDARD WALL FACADE SPECIAL DETAILS (CONTINUED)

#### PANEL DETAIL

When the facade is complete, the service panel must remain removable. 'A' represents the unobstructed path of the panel for removal. 'B' represents the width necessary to keep that path clear. 'C' represents the extra space necessary to accommodate any tile work, etc., that will be placed on top of the wall frame. 'C' is important as many installers leave enough clearance to remove the panel when the wall is bare, but not enough for when it is finished.

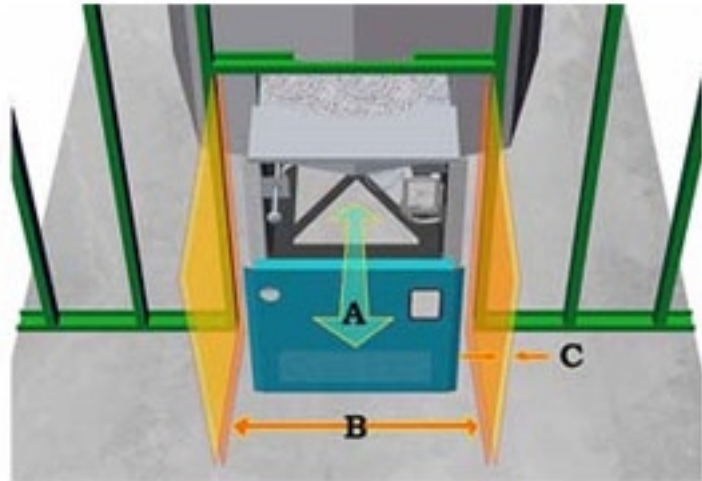

A facade will make for a functional installation as long as the following conditions are met:

1. Service can be performed from the **FRONT** of the oven by opening doors or panels to reveal the removable service panel.
2. There is sufficient airflow from the front of the house.
3. The radiant control knob is accessible. (See **Radiant Knob Detail** on page 8).

#### AIRFLOW DETAIL

Air flows to the under part of the oven through a vent on the front of the service panel and the air intake panel located between the service panel and the toe kick.

This area must be free of obstructions to allow proper airflow. The burners in the gas oven will not operate without sufficient combustion air. To avoid common installation mistakes that affect airflow, please read through the **Do's and Don'ts of Oven Venting** (found on the website).

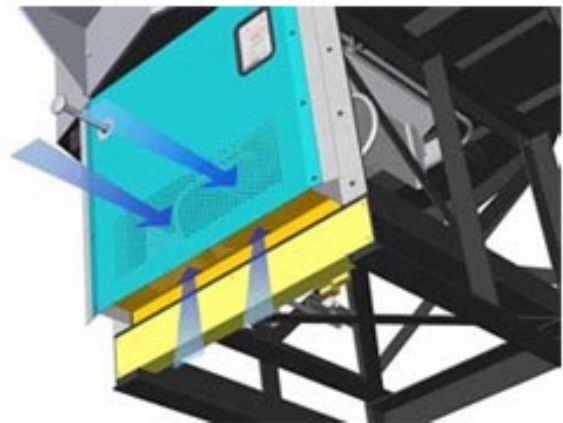

### STANDARD WALL FACADE SPECIAL DETAILS (CONTINUED)

#### WELD DETAIL

**Note:** The site-built doorway extension is welded snug to the doorway lip and does not block airflow out of the oven. The flange around it also allows room for the wallboard, tile and stud construction ('A'). Everything that touches the oven (and the mantle) must be non-combustible. Everything over the doorway must be non-combustible.

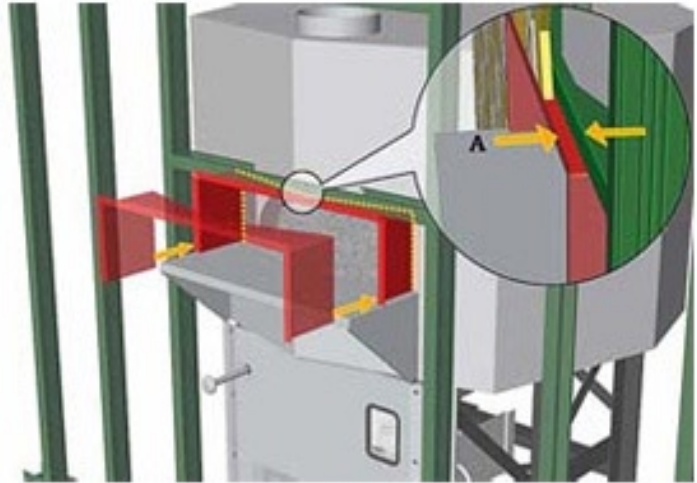

#### RADIANT KNOB DETAIL

**Note:** The site-built doorway extension is welded snug to the doorway lip and does not block airflow out of the oven. The flange around it also allows room for the wallboard, tile and stud construction ('A'). Everything that touches the oven (and the mantle) must be non-combustible. Everything over the doorway must be non-combustible.

